

# GEOKON®

48 Spencer Street  
Lebanon, NH 03766, USA  
Tel: 603-448-1562  
Fax: 603-448-3216  
Email: [geokon@geokon.com](mailto:geokon@geokon.com)  
<http://www.geokon.com>

*Instruction Manual*  
**Model 6850**  
3D Pendulum Readout



No part of this instruction manual may be reproduced, by any means, without the written consent of Geokon®.

The information contained herein is believed to be accurate and reliable. However, Geokon® assumes no responsibility for errors, omissions or misinterpretation. The information herein is subject to change without notification.

Copyright © 2010-2019 by Geokon®  
(Revision REV E 07/29/19)



## ***Warranty Statement***

Geokon warrants its products to be free of defects in materials and workmanship, under normal use and service for a period of 13 months from date of purchase. If the unit should malfunction, it must be returned to the factory for evaluation, freight prepaid. Upon examination by Geokon, if the unit is found to be defective, it will be repaired or replaced at no charge. However, the WARRANTY is VOID if the unit shows evidence of having been tampered with or shows evidence of being damaged as a result of excessive corrosion or current, heat, moisture or vibration, improper specification, misapplication, misuse or other operating conditions outside of Geokon's control. Components which wear or which are damaged by misuse are not warranted. This includes fuses and batteries.

Geokon manufactures scientific instruments whose misuse is potentially dangerous. The instruments are intended to be installed and used only by qualified personnel. There are no warranties except as stated herein. There are no other warranties, expressed or implied, including but not limited to the implied warranties of merchantability and of fitness for a particular purpose. Geokon is not responsible for any damages or losses caused to other equipment, whether direct, indirect, incidental, special or consequential which the purchaser may experience as a result of the installation or use of the product. The buyer's sole remedy for any breach of this agreement by Geokon or any breach of any warranty by Geokon shall not exceed the purchase price paid by the purchaser to Geokon for the unit or units, or equipment directly affected by such breach. Under no circumstances will Geokon reimburse the claimant for loss incurred in removing and/or reinstalling equipment.

Every precaution for accuracy has been taken in the preparation of manuals and/or software, however, Geokon neither assumes responsibility for any omissions or errors that may appear nor assumes liability for any damages or losses that result from the use of the products in accordance with the information contained in the manual or software.

# TABLE of CONTENTS

<b>1. OPERATING PRINCIPLE</b> .....	<b>1</b>
<b>2. TECHNICAL FEATURES</b> .....	<b>2</b>
<b>3. SYSTEM COMPONENTS</b> .....	<b>3</b>
<b>4. INSTALLATION</b> .....	<b>4</b>
4.1 INITIAL CHECKS .....	4
4.2 ORIENTATION AND PLACEMENT .....	4
4.3 DIRECT PENDULUM INSTALLATION.....	6
4.3.1 <i>Pendulum Table</i> .....	6
4.3.2 <i>System Assembly</i> .....	8
4.4 INVERTED PENDULUM INSTALLATION .....	12
4.4.1 <i>Inverted Pendulum Table Assembly</i> .....	12
4.4.2 <i>System Assembly</i> .....	14
<b>5. DATA ACQUISITION AND REMOTE MONITORING</b> .....	<b>19</b>
5.1 DATA PROCESSING .....	19
5.2 RS 485 COMMUNICATIONS .....	19
5.3 4-20MA ANALOGUE OUTPUT .....	20
5.4 WIRING DIAGRAMS .....	20
<b>6. CCDTEST SOFTWARE</b> .....	<b>22</b>
6.1 INITIAL SETUP .....	22
6.2 SETTINGS.....	24
6.2.1 <i>Change a Sensor's Address</i> .....	24
6.2.2 <i>Parameter Setting</i> .....	26
6.2.3 <i>Initialization</i> .....	26
6.2.4 <i>Reference Setting</i> .....	27
6.2.5 <i>Clock Setting</i> .....	30
6.3 QUITTING THE PROGRAM .....	30
<b>7. TROUBLESHOOTING</b> .....	<b>31</b>
<b>APPENDIX A. TECHNICAL SPECIFICATIONS</b> .....	<b>32</b>
<b>APPENDIX B. MULTILOGGER SOFTWARE CONFIGURATION</b> .....	<b>33</b>
B.1 OVERVIEW.....	33
B.2 WIRING.....	33
B.3 4-20MA CONFIGURATION .....	34
B.4 RS-485 CONFIGURATION.....	35
B.5 ERROR CODES .....	37
<b>APPENDIX C. PENDULUM COMMANDS</b> .....	<b>38</b>
<b>APPENDIX D. CR6 PROGRAMMING EXAMPLE</b> .....	<b>39</b>
<b>APPENDIX E. CR800/CR1000 PROGRAMMING EXAMPLE</b> .....	<b>42</b>
<b>APPENDIX F. MOUNTING BRACKET (OPTIONAL ACCESSORY)</b> .....	<b>43</b>
F.1 MOUNTING BRACKET INSTALLATION .....	43

# FIGURES

FIGURE 1 - SYSTEM OF CCD IMAGING.....	1
FIGURE 2 - ELECTRICAL SCHEMATIC.....	1
FIGURE 3 - MODEL 6850-5 3D PENDULUM READOUT.....	3
FIGURE 4 - 6850-5 DIMENSIONS AND ORIENTATION.....	5
FIGURE 5 - MEASUREMENT TABLE FOR DIRECT PENDULUM GENERAL ASSEMBLY GUIDE.....	6
FIGURE 6 - DIRECT PENDULUM MEASUREMENT TABLE ASSEMBLY PRINT.....	7
FIGURE 7 - MOUNTING BRACKETS WITH TWISTED WIRE.....	8
FIGURE 8 - TIGHTEN THE SET SCREW TO THE WIRE.....	9
FIGURE 9 - POSITIONING OF THE Z-BLOCK.....	9
FIGURE 10 - DIRECT PENDULUM SYSTEM WITH MEASUREMENT TABLE.....	10
FIGURE 11 - LIGHT SHIELDS INSTALLED.....	10
FIGURE 12 - CONICAL DRIP SHIELD INSTALLED.....	11
FIGURE 13 - MEASUREMENT TABLE FOR INVERTED PENDULUM GENERAL ASSEMBLY GUIDE.....	12
FIGURE 14 - INVERTED PENDULUM MEASUREMENT TABLE ASSEMBLY PRINT.....	13
FIGURE 15 - POSITIONING OF THE Z-BLOCK.....	16
FIGURE 16 - LIGHT SHIELDS INSTALLED.....	17
FIGURE 17 - INVERTED PENDULUM SYSTEM.....	17
FIGURE 18 - CONICAL DRIP SHIELD INSTALLED.....	18
FIGURE 19 - THE RS 485 ADDRESSABLE NETWORK.....	19
FIGURE 20 - CCD TEST USER INTERFACE.....	22
FIGURE 21 - SELECT COMMPORT.....	22
FIGURE 22 - SEARCH SENSORS.....	23
FIGURE 23 - SENSOR ADDRESS.....	23
FIGURE 24 - TIME STAMPED X AND Y READINGS.....	23
FIGURE 25 - SETTINGS DROPDOWN.....	24
FIGURE 26 - SET SENSOR'S ADDRESS FORM.....	24
FIGURE 27 - ADDRESS SET SUCCESSFULLY.....	24
FIGURE 28 - COMMERROR CAUSED BY INCORRECT SENSOR ADDRESS.....	25
FIGURE 29 - UPDATED SENSOR ADDRESS.....	25
FIGURE 30 - PARAMETER SETTINGS WINDOW.....	26
FIGURE 31 - SWAP READOUT OF X AND Y.....	26
FIGURE 32 - INVERT WINDOW, USED TO REVERSE THE DIRECTION OF AN AXIS.....	27
FIGURE 33 - REFERENCE SETTING WINDOW.....	28
FIGURE 34 - REFERENCE SETTING MESSAGE.....	28
FIGURE 35 - UPDATED X AND Y VALUES COINCIDING WITH REFERENCE CHANGES.....	29
FIGURE 36 - SET PENDULUM TIME TO MATCH PC CLOCK.....	30
FIGURE 37 - 4-20MA CONNECTION DIAGRAM.....	34
FIGURE 38 - LINEAR COEFFICIENTS.....	34
FIGURE 39 - RS-485 CONNECTION DIAGRAM.....	35
FIGURE 40 - TYPICAL RS-485 CHANNEL CONFIGURATION.....	35
FIGURE 41 - CHANNEL 1, X-AXIS CONFIGURATION.....	36
FIGURE 42 - CHANNEL 2, Y-AXIS CONFIGURATION.....	36
FIGURE 43 - MOUNTING BRACKET.....	43

## TABLES

TABLE 1 - POWER CORD CONNECTIONS .....	20
TABLE 2 - RS485A CONNECTOR .....	20
TABLE 3 - 4-20MA AND RS485A SIGNAL WIRING .....	21
TABLE 4 - ERROR CODES AND TROUBLESHOOTING INFORMATION.....	31
TABLE 5 - OUTPUT CONNECTOR PINOUT .....	33
TABLE 6 - MULTILOGGER ERROR CODES .....	37
TABLE 7 - COMMANDS FOR TERMINAL EMULATION PROGRAMS.....	38

## EQUATIONS

EQUATION 1 - MOVEMENT OF THE PENDULUM WIRE ALONG THE X-AXIS .....	19
EQUATION 2 - MOVEMENT OF THE PENDULUM WIRE ALONG THE Y-AXIS .....	19
EQUATION 3 - MOVEMENT OF THE PENDULUM WIRE ALONG THE Z-AXIS.....	19

## **1. OPERATING PRINCIPLE**

Geokon's model 6850-5 Three-Dimensional Pendulum Readout is designed for use with direct or inverted pendulums. The readout automatically measures horizontal deflections in two directions, as well as changes in the vertical distance between the top suspension point of the wire and the readout location. It is designed to measure the tilting of large structures such as dams, high-rise buildings, bridges, etc., and has a range of 50 mm x 100 mm x 50 mm (2" x 4" x 2").

Geokon's Pendulum Readouts utilize two high-resolution linear array Charge Coupled Devices (CCDs). Two collimated light sources, positioned at 90 degrees from each other, shine on the photosensitive CCD screens. When the shadow of the pendulum wire falls on the CCD sensors, an automatically generated scan of the CCD pixels maps, records, and digitally stores the coordinates of the shadow. See Figure 1.

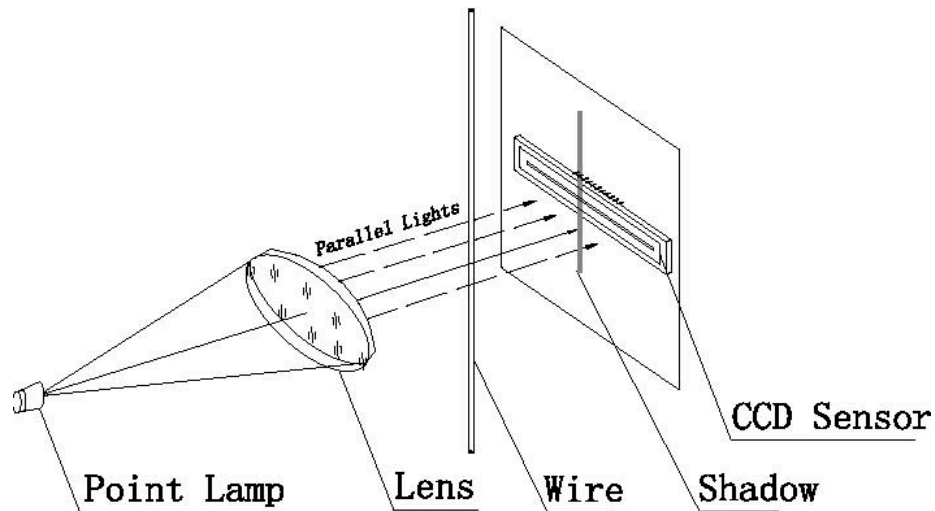

Figure 1 - System of CCD imaging

The information obtained by the CCD sensors is converted to an analog signal and displayed on the two LED panels mounted in the console. This signal can also be transmitted via 4-20mA output or RS-485 output to a remote readout site, as shown in Figure 2.

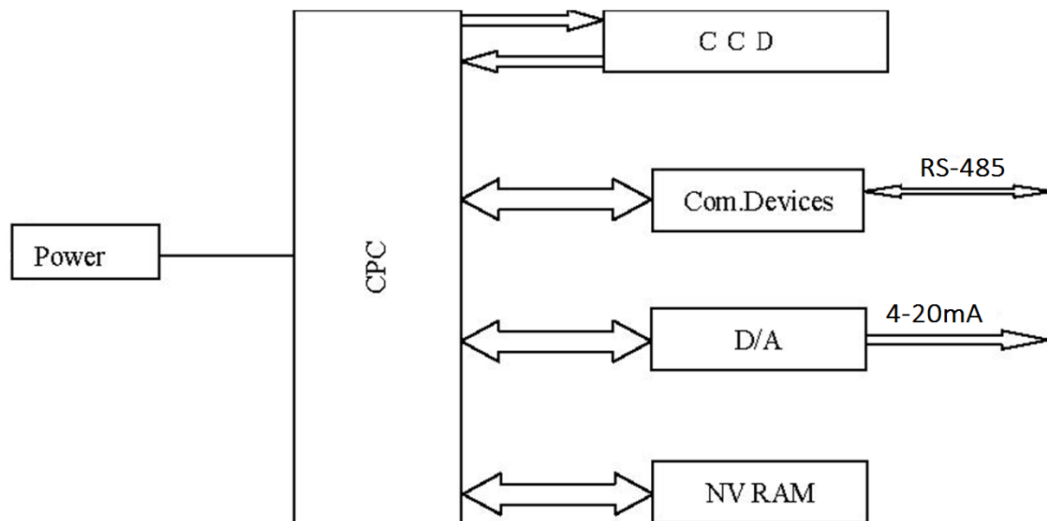

Figure 2 - Electrical Schematic

## **2. TECHNICAL FEATURES**

- Noncontact, three-dimensional measurement using CCD photoelectric imaging with a horizontal measurement range of 50 mm x 100 mm (2" x 4"), a vertical measurement range of 50 mm (2") and a resolution of 0.01 mm (.0004").
- High Precision, no electrical drift, good long-term stability.
- Strong ambient light resistance.
- Three built-in 4-digit LED visual display panels facilitate installation, debugging, and manual observation of the three-axis pendulum wire coordinates.
- Selectable sampling rate intervals from every 10 seconds to once per day.
- RS-485 output coupled with an addressable network function makes it possible for several 6850 3D pendulum readouts to be interconnected and addressed remotely and separately.
- 4-20mA output enables the 6850 pendulum readout to be compatible with all standard data acquisition and SCADA systems.
- Up to 1200 sets of measurement data can be stored.
- Power-Off protection with non-volatile storage ensures no data loss in the event of a power failure.
- Sealed modular construction, moisture proof circuitry, and a compact, sturdy, weatherproof cabinet ensure reliable performance in environments of up to 95% humidity (non-condensing).
- A slot in the cabinet enables it to be placed around the pendulum wire without dismantling the pendulum system.
- The built in power supply works worldwide and is compatible with voltages ranging from 85V to 265VAC.
- Self-diagnosis feature displays error codes by which a fault can be traced and corrected.
- An optional drip shield may be purchased, which clamps to the pendulum wire and prevents ambient light and water droplets from entering the CCD chamber of the readout.
- Direct Pendulum systems can be ordered with a measurement table for mounting the readout. Custom Brackets can be made to order to facilitate the mounting of the cabinet onto a vertical wall behind the pendulum wire.
- Inverted Pendulum systems can be ordered with a measurement table that allows the cabinet to be mounted directly below the float tank. Custom tables and float chambers can be made to order.



### **3. SYSTEM COMPONENTS**

Figure 3 shows the components of the 6850-5 Pendulum Readout, consisting of the cabinet with built in slot for pendulum wire, LED display panel, output connector, power input, CCD chamber, and a mounting plate on the side to mate with an optional universal mounting bracket.

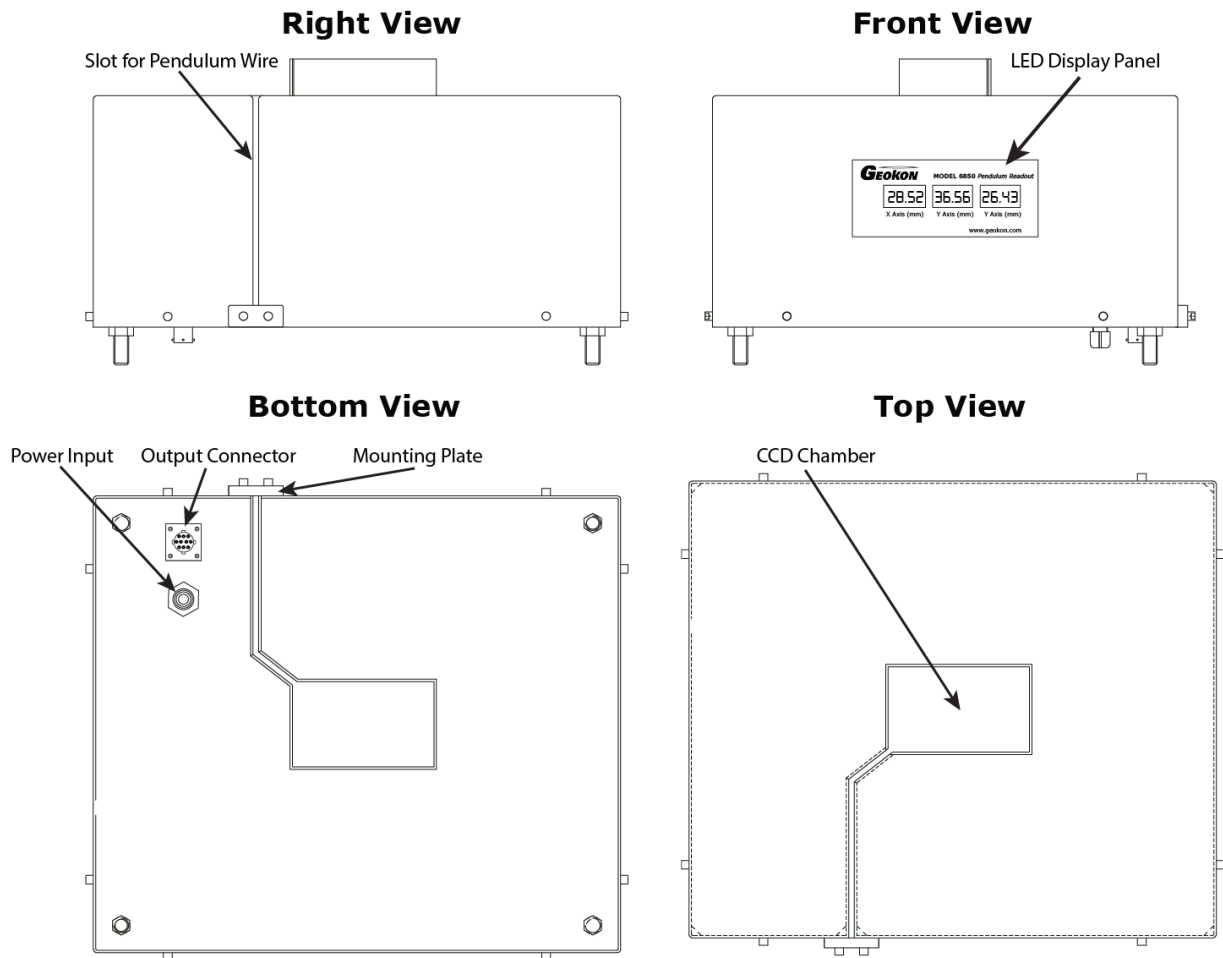

**Figure 3 - Model 6850-5 3D Pendulum Readout**

Each pendulum readout comes with the following accessories: An upper and lower light shield, CCDTest software, power cord, readout cable, RS-232 to RS-485 converter, Z-block, and four mounting bolts for solid mounting or raising the electronics.

An optional drip shield may be purchased, which clamps to the pendulum wire and prevents ambient light and water droplets from entering the CCD chamber of the readout.

Normal Pendulum Systems (Model 6850-2-1) contain the pendulum readout and its accessories plus a pendulum weight, hanger, damping tank and measurement table.

Inverted Pendulum Systems (Model 6850-2-2) contain the pendulum readout and its accessories plus a pendulum anchor, float tank, float, and measurement table.

## **4. INSTALLATION**

### **4.1 Initial Checks**

- 1) Check the cabinet for signs of external damage. If any damage is found, contact Geokon.
- 2) Connect to the power supply.
- 3) Cover the top and bottom of the square hole leading to the CCD chamber so that no light can enter. The readout display should read 'Err 4' indicating that the shadow of the pendulum wire is absent.
- 4) Insert a needle or a piece of wire approximately 1.6 mm (0.63") in diameter into the CCD chamber in order to simulate the pendulum wire. A reading should register on the X and Y LED displays.
- 5) When the needle or wire is centered, the Y-axis should read 50.00 mm and the X-axis should read 25 mm. (A 4-20mA reading should be approximately 12mA). Moving the needle back and forth should change the readings from 0 to 50 mm for the X-axis and 0 to 100 mm for the Y-axis.
- 6) To check the Z-axis, clamp the conical Z-block (supplied) to the wire with the flat face uppermost, and move the Z-block up and down. The Z-axis readings should change from 0 to 50 mm as the block is moved.

### **4.2 Orientation and Placement**

Figure 4 on the following page shows the dimensions of the pendulum readout, as well as the orientation and direction of positive changes in the displacement of the X and Y-axes when looking down at the top of the cabinet. For dams, the usual convention is to orient the cabinet so that the positive direction of the Y-axis points downstream, and the positive direction of the X-axis points towards the right bank, the right bank being the bank on the right when facing downstream.

Note that with this orientation, for direct pendulums, a downstream movement of the dam wall, (produced by an increase in the height of water behind the dam), will produce a positive increase in the Y-axis direction, whereas, for a reverse pendulum the same movement would produce a negative change in the Y-axis direction. To avoid confusion, it is best to check the orientations by examination once the installation has been made.

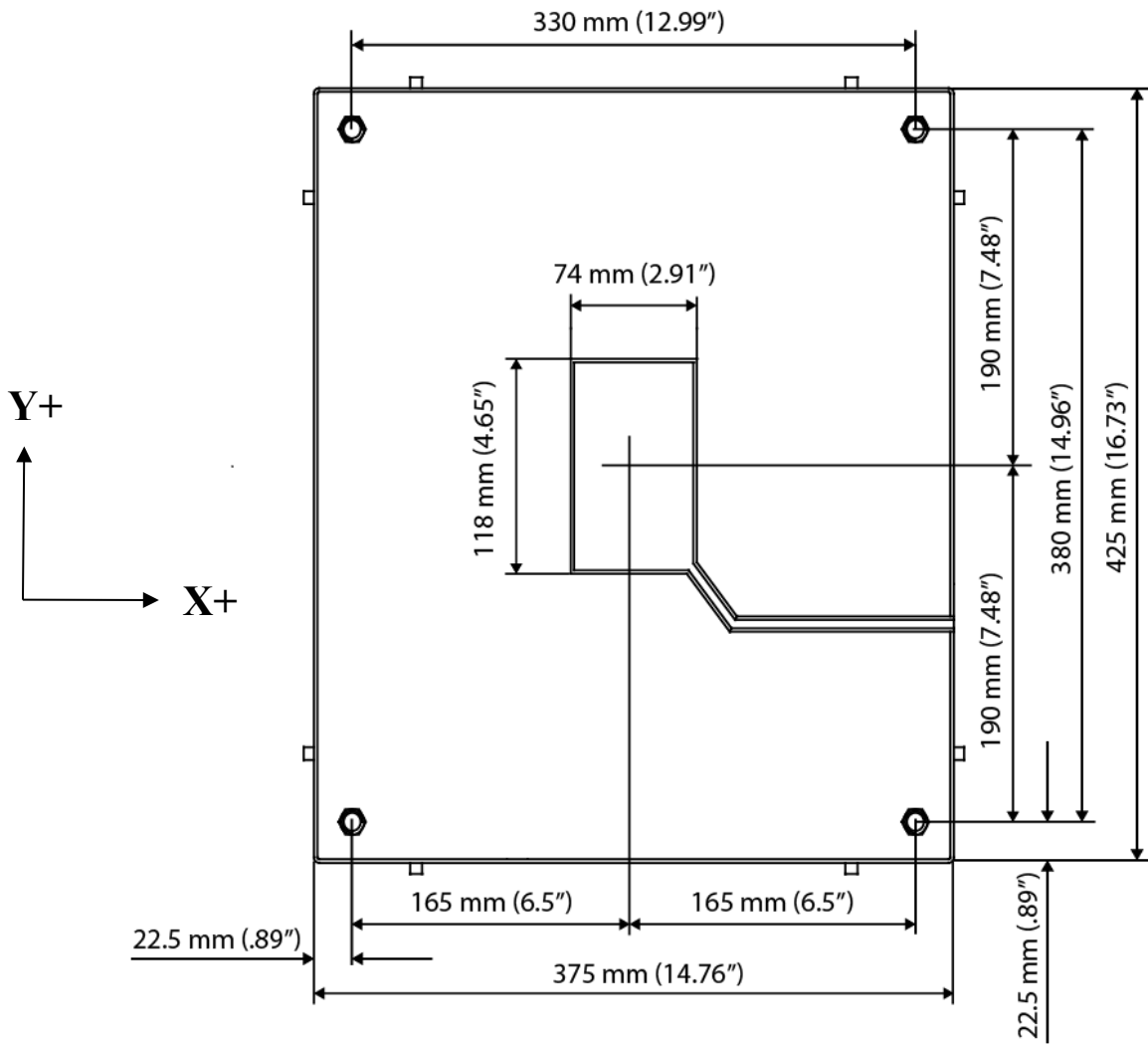

Figure 4 - 6850-5 Dimensions and Orientation

### 4.3 Direct Pendulum Installation

Model 6850-2-1 direct pendulum systems and intermediate stations require that the cabinet be mounted either on a measurement table or on a mounting bracket bolted to a vertical wall. Wall mounting brackets can be made locally, or by Geokon if the necessary dimensions and orientation are provided. See Appendix F for mounting bracket instructions.

#### 4.3.1 Pendulum Table

If the pendulum readout was purchased with a measurement table, assemble it per the print shown in Figure 6. The pictures shown in Figure 5 can be used as a general assembly guide.

**IMPORTANT NOTE: If the hanging pendulum wire is already in place, assemble the table around the wire.**



Figure 5 - Measurement Table for Direct Pendulum General Assembly Guide

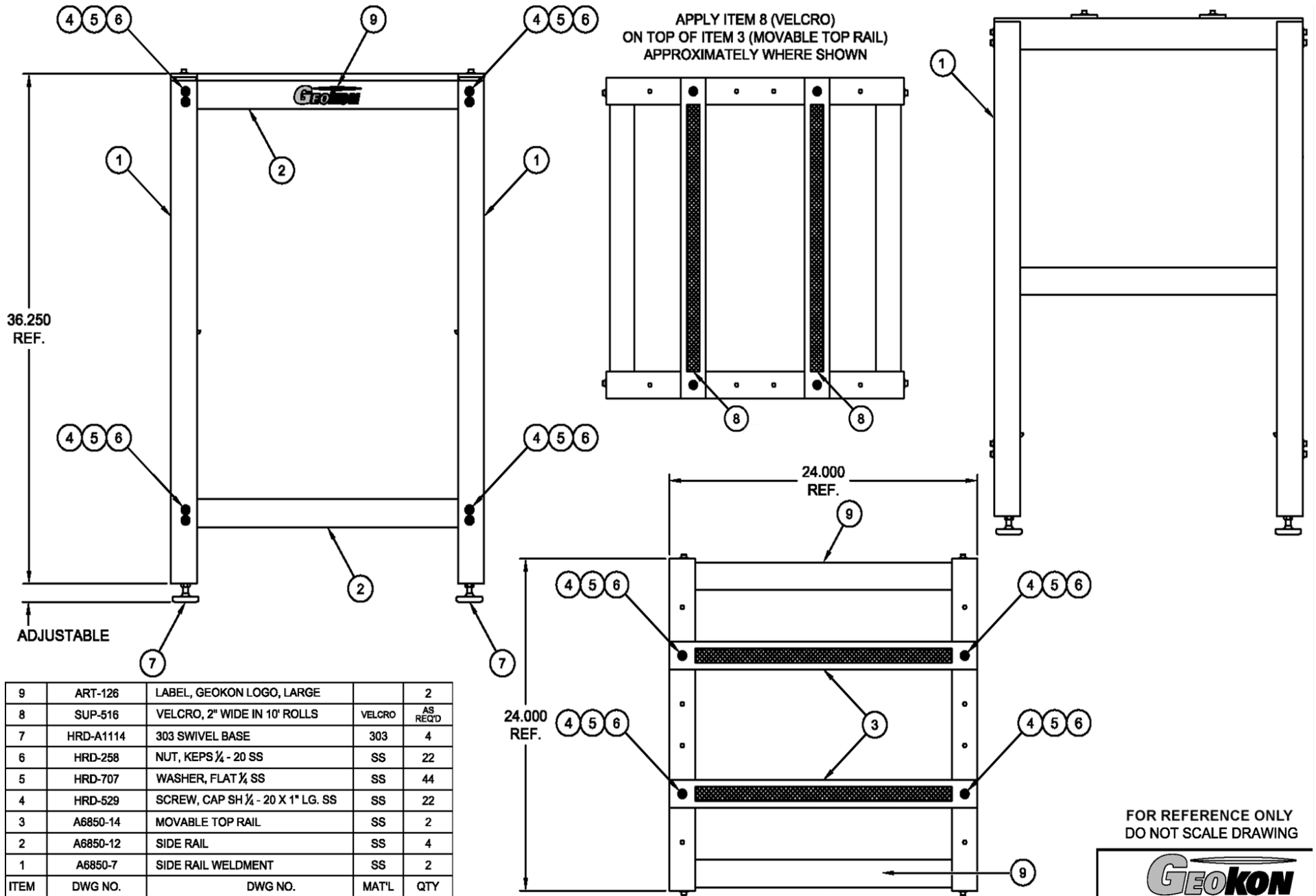
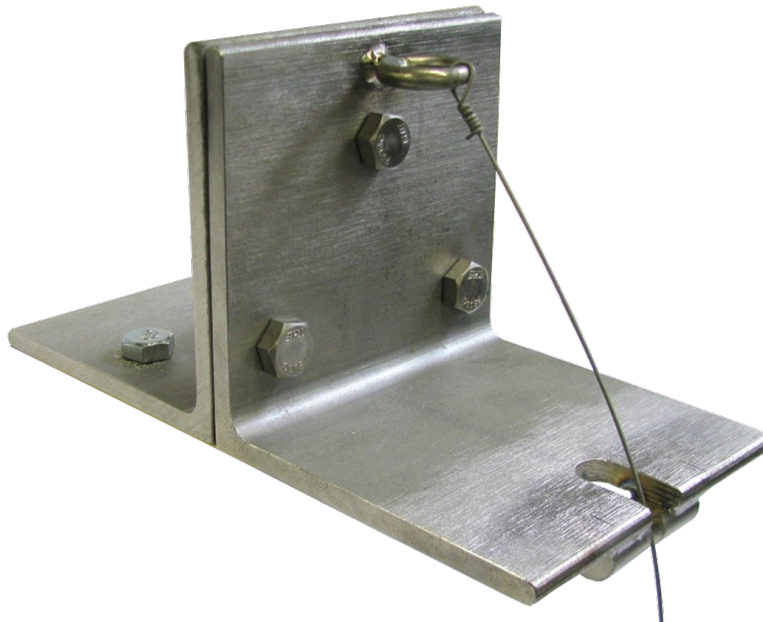

Figure 6 - Direct Pendulum Measurement Table Assembly Print

### 4.3.2 System Assembly

- 1) The wire for the direct pendulum system is normally anchored at the top of a borehole or in the roof of the gallery directly above the drill hole. If the wire is to be anchored to the floor at the top of the drill hole, two angle brackets are required (as shown in Figure 7); if it will be anchored to the ceiling over the hole, only the bracket with the wire guide is used. Mount the angle bracket(s) as follows:
  - a. Mark the location of the three mounting holes in the bracket.
  - b. Using a hammer drill, drill a 12 mm (1/2") hole, approximately 37 mm (1.5") deep at each of the markings.
  - c. Clean the holes thoroughly, blow them out with compressed air if possible.
  - d. Insert the drop-in anchors into the holes. The threaded end of the anchor should be facing out.
  - e. Using the supplied setting pin tool and a hammer set the anchor by striking the setting pin with two or three sharp blows.
  - f. Place a washer over each of the cap screws.
  - g. Attach the bracket to the ceiling by tightening the cap screws into the anchors using the supplied Allen wrench.
  
- 2) Attach the pendulum wire to the bracket by feeding it through the wire guide and the eye and then twisting it around itself (Figure 7).



**Figure 7 - Mounting Brackets with Twisted Wire**

- 3) Cut the pendulum wire so that when the weight is attached it will be suspended about 50 mm (2") above the floor. (The wire will stretch approximately 25 mm [1"] for every 30 m [100'] of length.)
- 4) Position the measurement table so that the pendulum wire hangs in its center. Orient the table so that the two plates the pendulum readout will sit on are facing in the upstream/downstream direction.
- 5) With the aid of a spirit level, level the table using the adjustment screws on the feet.

- 6) Push the pendulum wire into the wire grip at the top of the weight until it stops.
- 7) Tighten the setscrew against the wire with the wrench provided (Figure 8). Do not use excessive force (18 in/lbs.); experiment with a short piece of wire first.

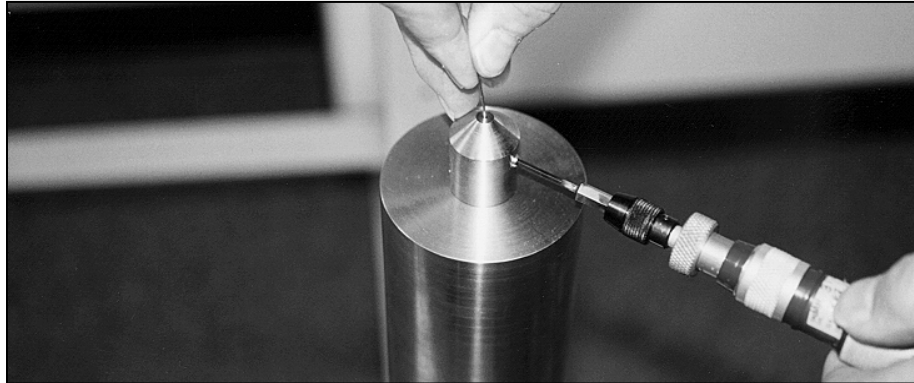

**Figure 8 - Tighten the Set Screw to the Wire**

- 8) Place the tank underneath the measurement table.
- 9) Allow the weight to hang inside the tank.
- 10) Make any adjustments needed to position the weight correctly inside the tank and then fill the tank with water (or antifreeze solution).
- 11) Position the Z-block on the pendulum wire at a height of approximately 100 mm (4") above the pendulum table. Using a Phillips head screwdriver, tighten the two screws in the Z-block so that it clamps onto the pendulum wire. Figure 9 shows the positioning of the Z-block.

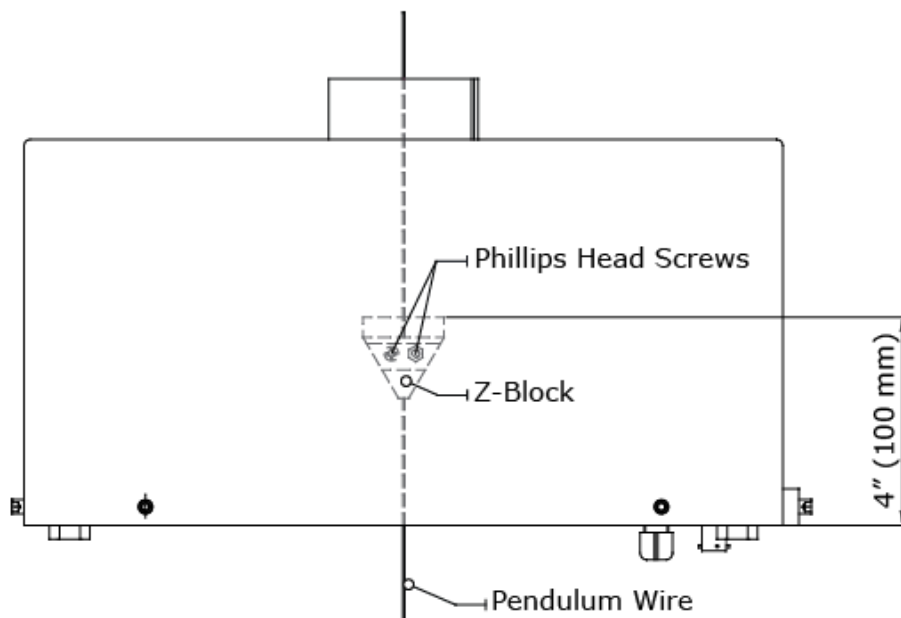

**Figure 9 - Positioning of the Z-block**

- 12) Place strips of Velcro on the bottom of the readout in such a manner that they will align with the strips on the pendulum table when the readout is set in position.



- 13) With the readout above the Z-block, slide the wire through the slot in the readout.
- 14) Orient the Y-axis of the readout so that it points in an upstream/downstream direction; orient the X-axis so that the positive direction points towards the right bank. The cabinet can be positioned so that the wire is centered in the CDC chamber, or offset to accommodate the maximum movements anticipated.
- 15) Carefully lower the cabinet onto the readout table, making sure the Z-block does not scratch the photosensitive screens inside the CCD chamber while doing so. Align the Velcro strips on the bottom of the cabinet with the ones on the mounting surface. Figure 10 depicts the assembly thus far.

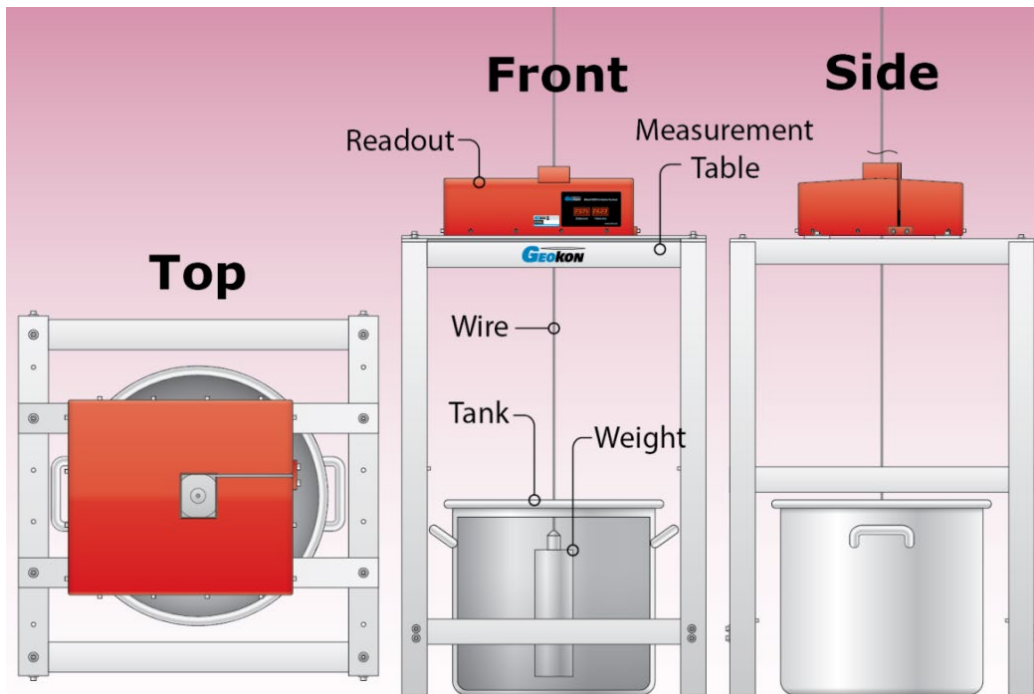

Figure 10 - Direct Pendulum System with Measurement Table

- 16) Attach the upper and lower light shields to the cabinet as shown in Figure 11.



Figure 11 - Light Shields Installed



- 17) If a conical drip shield was purchased, use the wrench provided to tighten the nylon set screws onto the pendulum wire. Leave about a 2.5 cm gap between the shield and the cabinet (Figure 12).



**Figure 12 - Conical Drip Shield Installed**

- 18) Take initial readings for both axes. See Section 5.1 for data processing.

#### 4.4 Inverted Pendulum Installation

Model 6850-2-2 Inverted Pendulum Systems are designed for use in dam embankments. The grout anchor is installed inside a vertical hole drilled or erected inside the embankment. This vertical hole must be of sufficient diameter so that the stainless steel wire, which is attached to the anchor, will never contact the sides of the hole.

The pendulum wire is kept vertical and taut by means of a float attached to the upper end of the wire. The float is installed inside a donut shaped tank, which is partially filled with water, causing the center of the float to always be vertically aligned with the anchor point. Any lateral displacement of the upper part of the dam embankment relative to the lower part – by either sliding or tilting – causes the float and the wire to move relative to the donut shaped tank, as well as to the table support on which the tank and electronic motion detector sit.

##### 4.4.1 Inverted Pendulum Table Assembly

If the pendulum readout was purchased with a measurement table, assemble it per the print shown in Figure 14. The pictures shown in Figure 13 can be used as a general assembly guide. **IMPORTANT NOTE: If the hanging pendulum wire is already in place, assemble the table around the wire.**



Figure 13 - Measurement Table for Inverted Pendulum General Assembly Guide

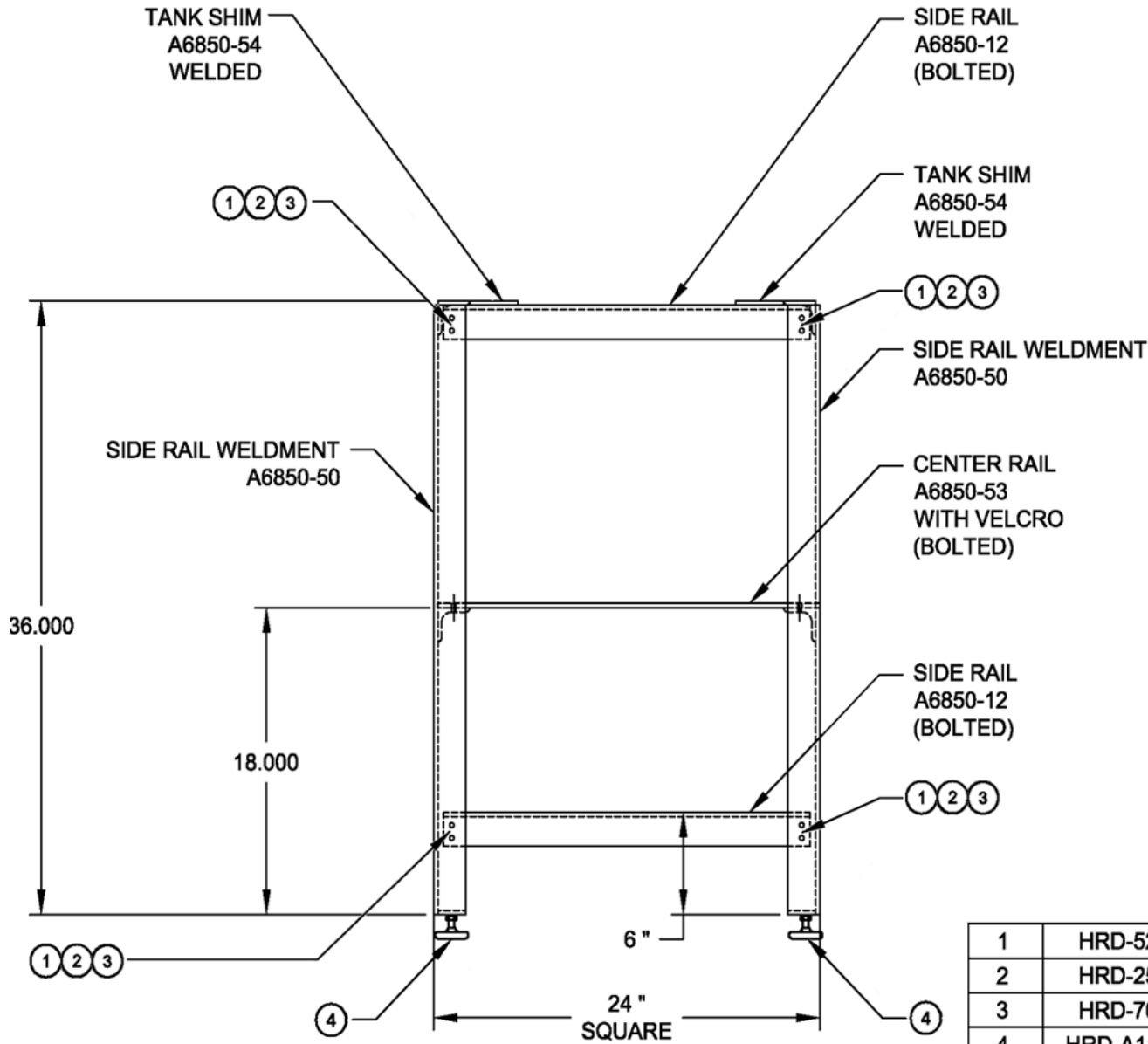

FOR REFERENCE ONLY  
DO NOT SCALE DRAWING



1	HRD-529	1/4 - 20 X 1" LG. SHCS SS	24
2	HRD-258	1/4 - 20 HEX KEP NUT SS	24
3	HRD-707	1/4" FLAT WASHER SS	48
4	HRD-A1114	303 SWIVEL BASE	4
ITEM	PART NO.	DESCRIPTION	QTY

MOUNTING HARDWARE

Figure 14 - Inverted Pendulum Measurement Table Assembly Print

#### 4.4.2 System Assembly

- 1) Assemble the two halves of the grout anchor by threading them together (Figure 15).

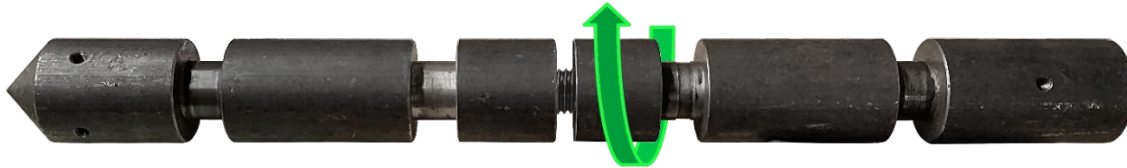

Figure 15 - Assemble the Two Large Anchor Pieces

- 2) Loosen or remove the Phillips head screws from the wire clamp. Slide the stainless steel wire through the back of the anchor nut, then through the *flat* side of the wire clamp (i.e., not the side with the conical indentation).

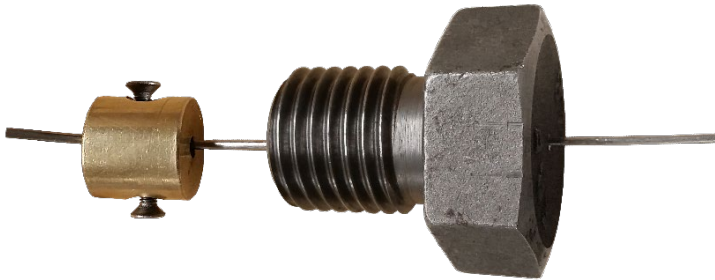

Figure 16 - Wire Inserted Through Anchor Nut and Wire Clamp

- 3) Loop the end of the stainless steel wire around the groove in the end block then slide it back through the wire clamp until it emerges on the other side. Push the wire clamp and the end block as close together as possible then tighten the two Phillips head screws to secure the wire in place. Figure 17 shows the completed end block and wire clamp assembly.

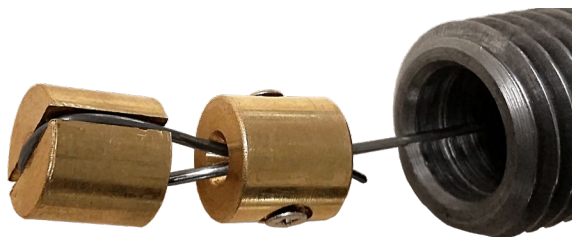

Figure 17 - End Block and Wire Clamp Assembly

- 4) Slide the end block and wire clamp into the anchor nut as shown in Figure 18.



Figure 18 - Wire Clamp and End Block Seated Inside Anchor Nut

- 5) Thread the anchor nut into the mating end of the anchor (Figure 19). The completed anchor and wire assembly is shown in Figure 20.



**Figure 19 - Anchor Nut Attachment**



**Figure 20 - Completed Anchor Assembly**

- 6) Tremie cement grout into the borehole so that when the grout anchor is lowered in the grout will almost cover it. The grout should be of a creamy consistency, similar to pancake batter.
- 7) Make centralizers out of wire or cardboard to hold the grout anchor in the middle of the borehole.
- 8) Lower the anchor into the grout and allow it to hang freely.
- 9) Keep the wire centered in the borehole while the grout is setting up.
- 10) Position the measurement table so that it is centered over the top of the borehole. Orient the table so that the two plates the pendulum readout will sit on are facing in the upstream/downstream direction.
- 11) With the aid of a spirit level, level the table using the adjustment screws on the feet.
- 12) Place the tank on top of the table.
- 13) Pass the wire up through the table and through the central hole in the tank.
- 14) Secure the clamp rod to the top of the float using the two large, knurled nuts.
- 15) Pass the wire up through the clamp rod and out the top.
- 16) Lower the float into the tank.
- 17) Push the end of the stainless steel wire through the hole in the upper wire clamp and out the hole in the side.
- 18) Push the upper wire clamp along the wire until it is approximately 50 mm (2") away from the top of the clamp rod.
- 19) Tighten the upper wire clamp onto the wire. Cut off any excess wire.

- 20) Pour water (or antifreeze solution) into the tank to raise the float and exert tension in the stainless steel wire. Continue to add water until the upper clamp can be seated inside the top of the clamp rod.
- 21) Makes sure the float is centralized within the tank.
- 22) Place the tank on top of the table so that it is positioned centrally around the float (move the table if necessary).
- 23) Add more water until the tension on the stainless steel wire is around 60 kilograms. (The float should be submerged approximately 200 mm [8"].)
- 24) Tighten the pin vise to the stainless steel wire.
- 25) Position the Z-block on the pendulum wire at a height of approximately 100 mm (4") above the center rails of the pendulum table. Using a Phillips head screwdriver, tighten the two screws in the Z-block so that it clamps onto the pendulum wire. Figure 21 shows the positioning of the Z-block.

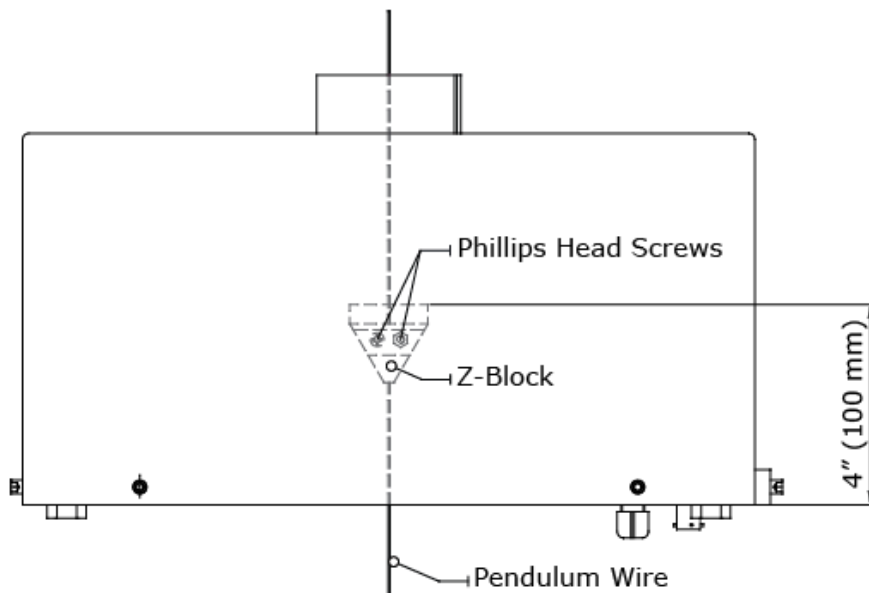

**Figure 21 - Positioning of the Z-block**

- 26) Place strips of Velcro on the bottom of the readout in such a manner that they will align with the strips on the pendulum table when the readout is set in position.
- 27) With the readout above the Z-block, slide the wire through the slot in the readout.
- 28) Orient the Y-axis of the readout so that it points in an upstream/downstream direction; orient the X-axis so that the positive direction points towards the right bank. The cabinet can be positioned so that the wire is centered in the CDC chamber, or offset to accommodate the maximum movements anticipated.



- 29) Carefully lower the cabinet onto the readout table, making sure the Z-block does not scratch the photosensitive screens inside the CCD chamber while doing so. Align the Velcro strips on the bottom of the cabinet with the ones on the mounting surface. Figure 23 depicts the assembly thus far.
- 30) Lower the readout onto the center rails of the table so that Velcro strips on the bottom of the cabinet contact the ones on the mounting surface.
- 31) Attach the upper and lower light shields to the cabinet as shown in Figure 22.



**Figure 22 - Light Shields Installed**

- 32) If a conical drip shield was purchased, use the wrench provided to tighten the nylon set screws onto the pendulum wire. Leave about a 2.5 cm gap between the shield and the cabinet (Figure 24).

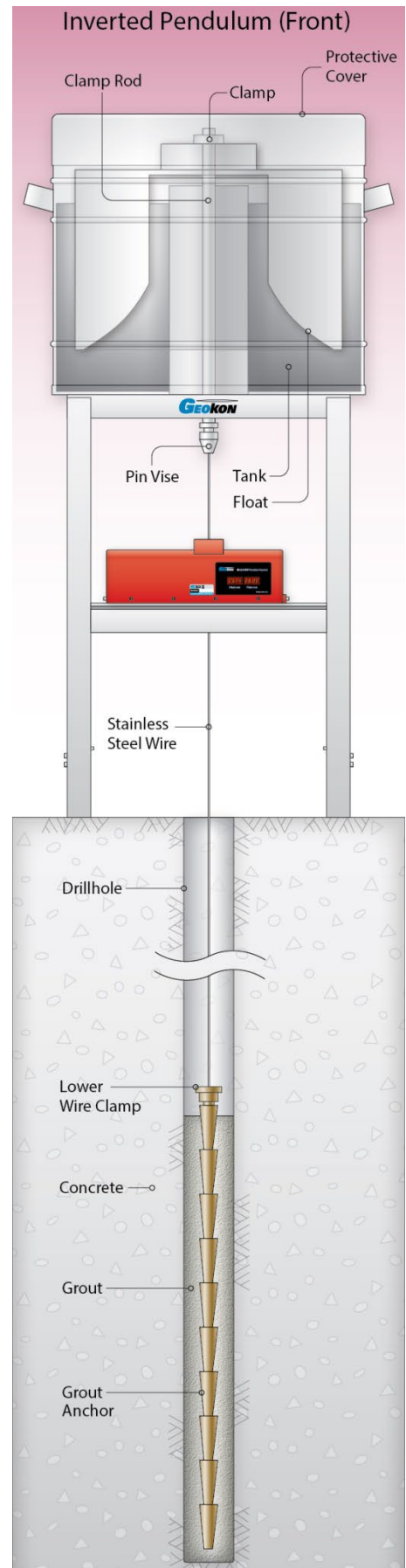

**Figure 23 - Inverted Pendulum System**



**Figure 24 - Conical Drip Shield Installed**

33) Take initial readings for both axes. See Section 5.1 for data processing.



## 5. DATA ACQUISITION AND REMOTE MONITORING

### 5.1 Data Processing

Initial values of X, Y, and Z should be obtained during installation.

Movements of the pendulum wire ( $\Delta X$ ,  $\Delta Y$ , and  $\Delta Z$ ) as displayed on the readout cabinet in mm are derived from the equations:

$$\Delta X = X_1 - X_0$$

Equation 1 - Movement of the Pendulum Wire Along the X-axis

$$\Delta Y = Y_1 - Y_0$$

Equation 2 - Movement of the Pendulum Wire Along the Y-axis

$$\Delta Z = Z_1 - Z_0$$

Equation 3 - Movement of the Pendulum Wire Along the Z-axis

Where;

$X_0$ ,  $Y_0$ , and  $Z_0$  are the initial readings of the axes.

$X_1$ ,  $Y_1$  and  $Z_1$  are subsequent readings on the axes.

When using the 4-20mA output the actual displacements of the wire in mm is obtained by multiplying each of the measured  $\Delta X$  and  $\Delta Z$  by the calibration factor **3.125 mm/mA** and the measured  $\Delta Y$  by **6.25 mm/mA**

### 5.2 RS 485 Communications

In addition to providing onsite monitoring, the 6850 Pendulum Readout also has an RS-485 digital interface. Each 6850 Pendulum Readout has a unique network address. Up to 32 pendulum readouts can be connected together through the RS 485 interface, as shown in Figure 25.

**CAUTION! To prevent damage to the communications port, the RS-485 connection must be three wire. In addition, all devices on the network must be connected to a common ground!**

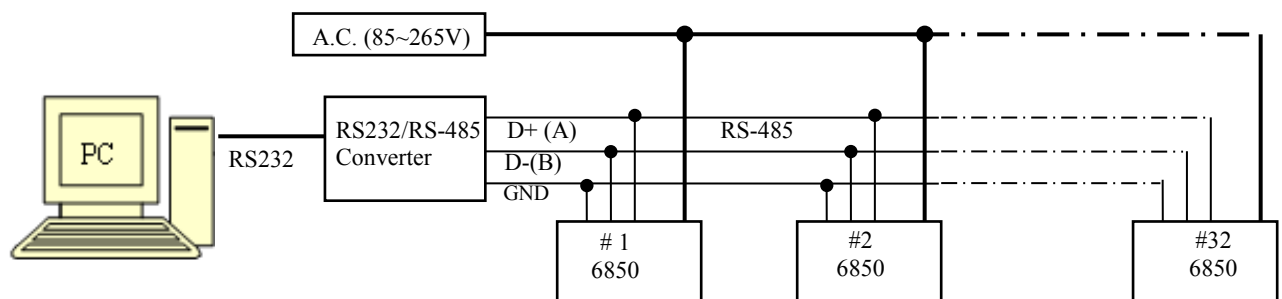

Figure 25 - The RS 485 Addressable Network

When using the RS 485 network the distance to the farthest pendulum should not exceed 1200 meters. In order to decrease signal reflectance, a 120-ohm resistance must be connected at the most remote pendulum, through a parallel connection to the RS 485 connector. If the transmission distance exceeds 1200 meters, a fiber optic cable can be used. (With fiber optic cables, there is no limit on the transmission distance and up to 99 pendulums can be connected into the network.)

### 5.3 4-20mA Analogue Output

In addition to providing onsite monitoring, the 6850 Pendulum Readout also has a 4-20mA analogue output. The pendulum readout's 4-20mA output can be measured using a high precision (0.1%) digital ammeter, e.g., the 20mA level of a 4.5-bit digital multimeter, or any standard datalogger. If ammeters are used, three are required per pendulum, one each of the axes.

### 5.4 Wiring Diagrams

The Power connector located on the base of the cabinet is wired as follows:

<b>Power Cord Three Conductor</b>	<b>Label</b>	<b>Function</b>
RED	L	Line
BLUE	N	Neutral
YELLOW	GND	Ground

**Table 1 - Power Cord Connections**

Every Pendulum Readout ships with an RS-485/4-20mA cable equipped with a 10-pin bulkhead connector. These cables are wired as shown in Table 2.

<b>10-pin socket (RS485 / Analog Output)</b>	<b>Definition</b>	<b>Description</b>
A	I <sub>x</sub>	X-axis analog output
B	GND	X-axis ground
C	I <sub>y</sub>	Y-axis analog output
D	GND	Y-axis ground
E	NC	null
F	A	RS485-T/R-
G	B	RS485-T/R+
H		null
K		Z-axis analog output
J		Z-axis ground

**Table 2 - RS485A Connector**

If the user receives communications cables already made up they are defined as follows:

<b>10-pin plug (RS232 / Analog Output)</b>	<b>Conductor color</b>	<b>Definition</b>	<b>Description</b>
A	RED	I <sub>x</sub>	X-axis analog output
B	RED'S BLACK	GND	X-axis ground
C	WHITE	I <sub>y</sub>	Y-axis analog output
D	WHITE'S BLACK	GND	Y-axis
E	SHIELD	GND	grounding
F	GREEN		RS 485 TD(A)
G	GREEN'S BLACK		RS 485 TD(B)
H		NC	null
K	YELLOW	I <sub>z</sub>	Z- axis analog output
J	YELLOW'S BLACK	GND	Z axis ground

**Table 3 - 4-20mA and RS485A Signal Wiring**

## **6. CCDTEST SOFTWARE**

***NOTE: These Instructions were written for the 2-axis pendulum but can be extrapolated to the 3-axis.***

Each Pendulum Readout comes with a copy of **CCDTest** software, which is used for setting the pendulum parameters and checking the operation of the unit. Use the supplied installer to install the software. (For details on how to use the Pendulum Readout with MultiLogger software, see Appendix B.)

### **6.1 Initial Setup**

Upon opening, the program will default to the main screen (Figure 26).

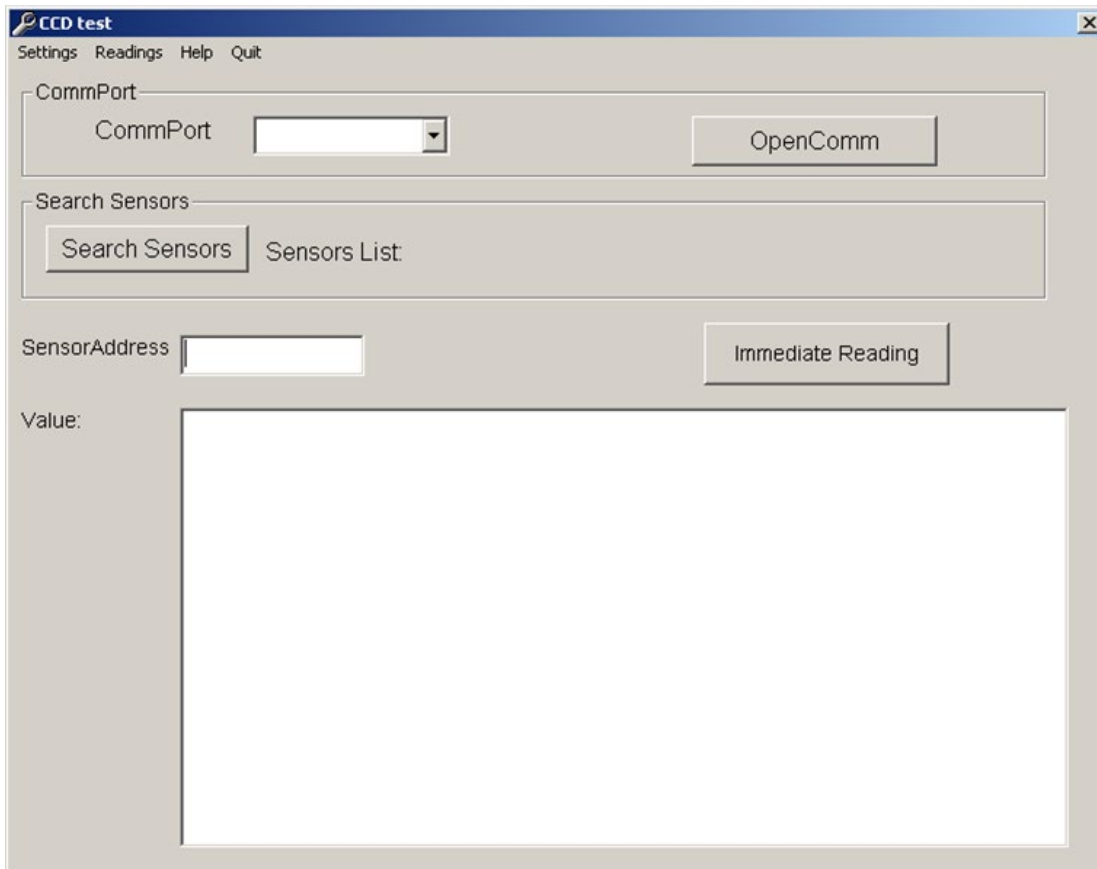

**Figure 26 - CCD Test User Interface**

In the **CommPort** section of the screen, select the CommPort that has the RS-485 adaptor attached, and then click **OpenComm** (Figure 27).

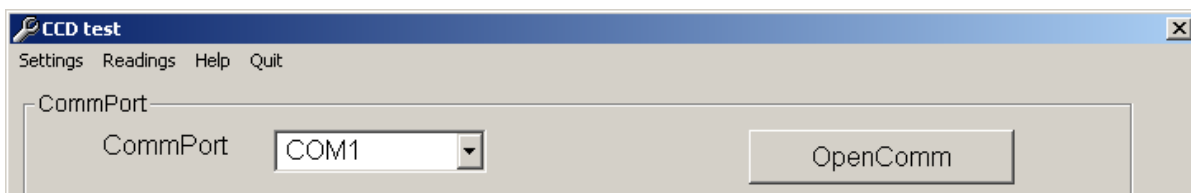

**Figure 27 - Select CommPort**

If unsure of the address, click the **Search Sensors** button. This will cause the software to attempt to locate the correct CommPort (Figure 28).

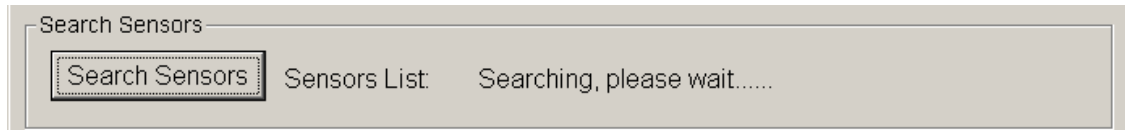

**Figure 28 - Search Sensors**

Sensors found will be shown in the **Sensors List**. Enter the Sensor Address of the pendulum the software will communicate with in the **SensorAddress** field. In Figure 29 below, sensor address 15 was found and subsequently entered into the SensorAddress field.

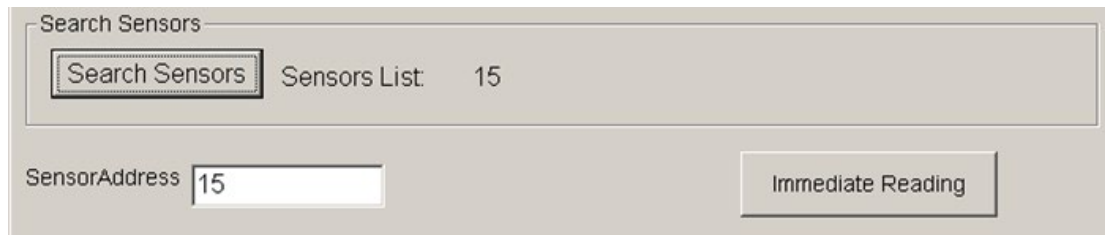

**Figure 29 - Sensor Address**

Clicking **Immediate Reading** will cause the program to take measurements from the attached pendulum every 10 seconds. These measurements will be displayed in the **Value:** section of the screen (Figure 30). From left to right the readings are displayed as follows: Time Stamp, X-axis Value, Y-axis value. Note any errors shown and troubleshoot if necessary. See Section 7 for troubleshooting tips and an explanation of the error codes. To clear the readings displayed in the Value field press the **Stop** button then restart the Immediate Readings.

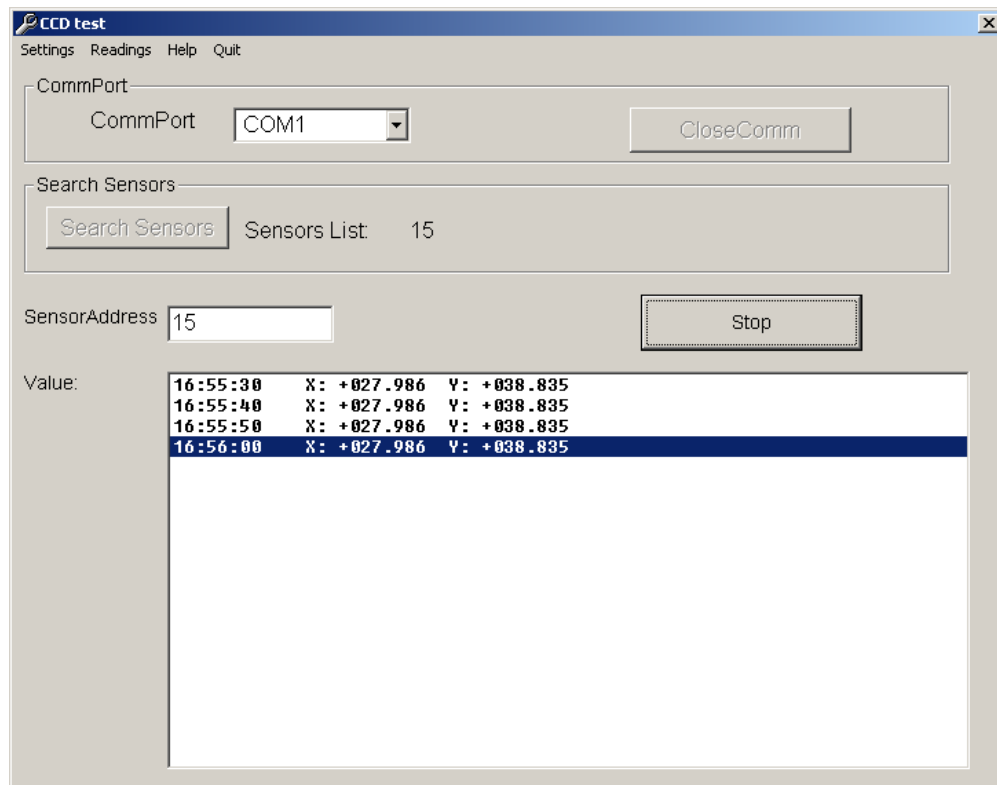

**Figure 30 - Time Stamped X and Y Readings**

## 6.2 Settings

The CCDTest software provides several functions related to the configuration of the pendulum. These options are made available by clicking on **Settings** in the upper left portion of the screen (Figure 31). The function of each available setting is described in the subsections below.

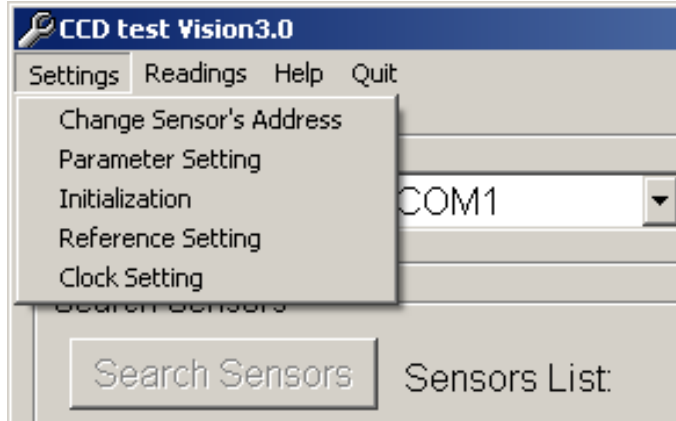

Figure 31 - Settings Dropdown

### 6.2.1 Change a Sensor's Address

Selecting **Change Sensor's Address** from the Settings dropdown list will cause the Set Sensor's Address form to display (Figure 32). Enter the **Original Address** followed by the **New Address**. Click **OK** when finished. In Figure 32, the sensor address is being updated from 15 to 1.



Figure 32 - Set Sensor's Address Form

The software will attempt to change the sensor address and then show a message stating if the address change was successful (Figure 33). Click **OK** to return to the Set Sensor's Address form.

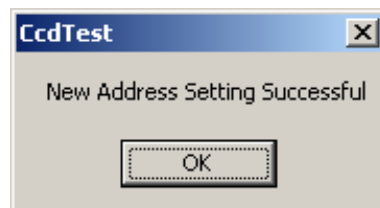
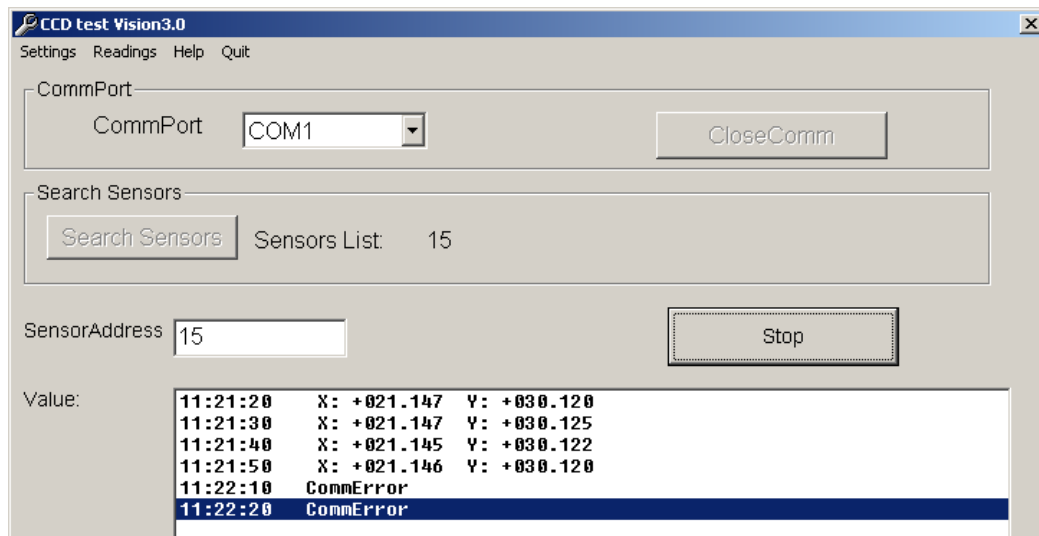

Figure 33 - Address Set Successfully

If the address change fails, try again with a new address. Once all desired address changes have been made, click the **Cancel** button to return to the main screen.

Once a sensor address has been changed, it must be updated in the **SensorAddress** field on the main screen. A **CommError** will be displayed until the new sensor address has been entered (Figure 34).



**Figure 34 - CommError Caused by Incorrect Sensor Address**

Once the Sensor Address field has been updated, the readings should display properly. In Figure 35 the sensor address has been updated from the original address of 15 to the new address of 1, causing the readings to display properly.

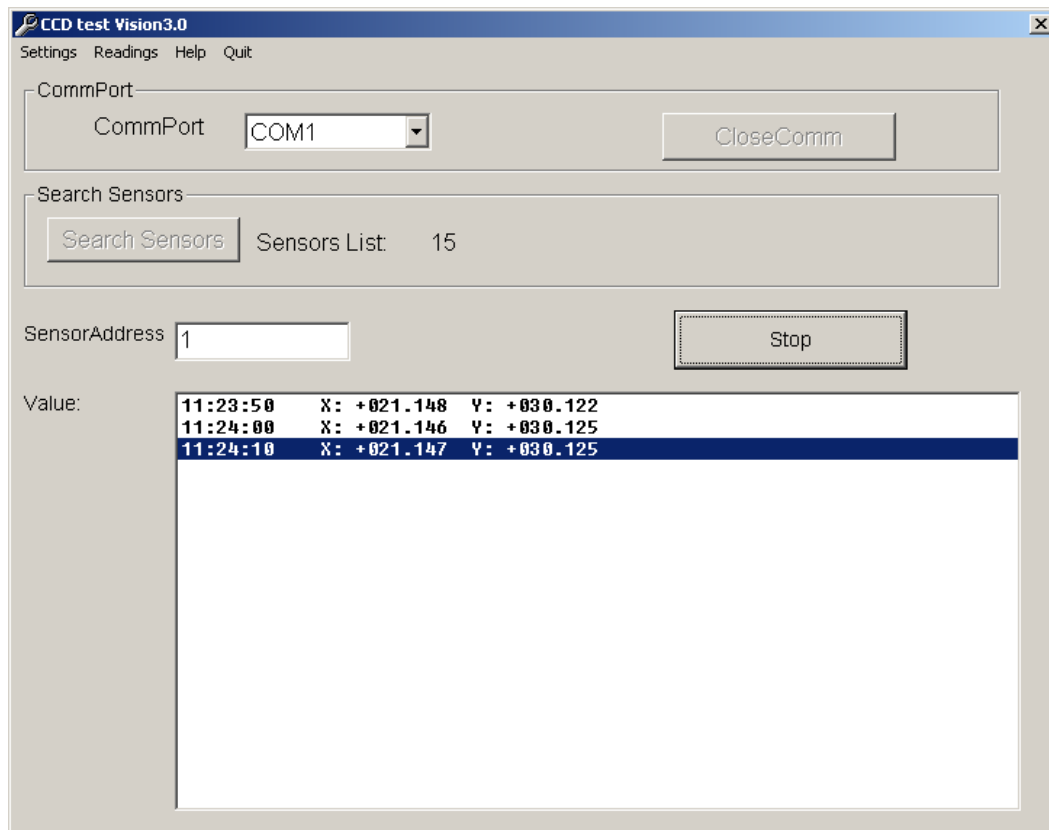

**Figure 35 - Updated Sensor Address**

## 6.2.2 Parameter Setting

Select **Parameter Setting** from the Settings menu to configure the wire diameter and the permitted error for each Pendulum (Figure 36).

Figure 36 - Parameter Settings Window

Enter the Sensor address the calibration parameters will be set for in the **Pendulum Readout Addr** field. Next, enter the wire diameter in millimeters in the **Diameter(mm)** field. Lastly, enter the desired permitted error in millimeters in the **Permitted Error(mm)** field. (The recommended Permitted Error is 0.5 mm.)

Once all the information has been entered, click **Set** to adjust the internal pendulum settings. The **Inquiry** button will populate the fields with the current pendulum settings. Click **Exit** when finished to return to the main screen.

## 6.2.3 Initialization

**Please Note: The pendulum address must be entered into the Sensor Address field on the main screen for these options to work correctly!**

Selecting **Initialization** from the Settings dropdown list will cause the **Swap** window to display (Figure 37). The swap window allows the X and Y axes of the pendulum to be interchanged. (This includes reversing the digital display and the 4-20mA outputs of the unit.) The default is False, meaning no change will take place. This may be changed to True by selecting True from the dropdown menu. If set to true the X and Y axes will be swapped. Once the desired setting has been selected press **Set**. Pressing **Query** will display the pendulum's current setting.

Figure 37 - Swap Readout of X and Y



Clicking **Next** in the Swap window will open the **Invert** window (Figure 38) which allows the direction of movement for the X or Y-axis to be reversed. This feature is useful where the installed orientation of the unit must match the direction of anticipated movement.

To change the direction of movement of an axis, use the dropdown under **X Direction** or **Y Direction** and change the value to **True**. For example, if the X-axis is currently reading 35.78 mm out of the 50 mm range, and the field under X-Direction is changed to true, it will now read 14.22 mm.

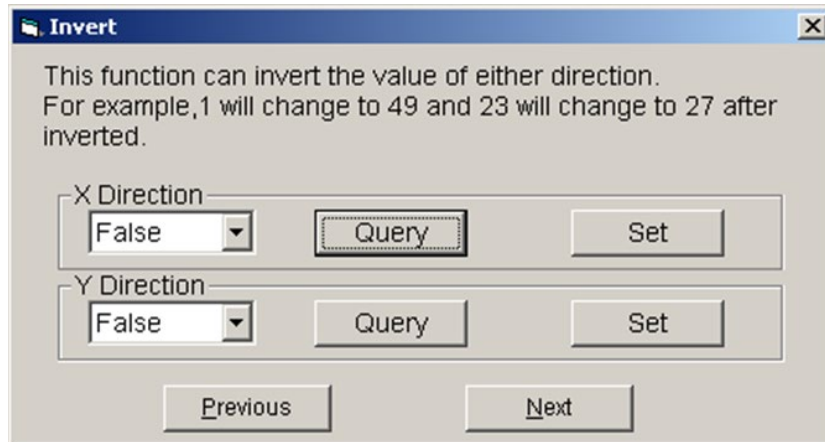

Figure 38 - Invert Window, used to Reverse the Direction of an Axis

Press **Set** to update the pendulum with the chosen settings. Press **Query** to view the current settings. When finished press **Next**; this will advance the program to the Reference Setting window detailed in the next section. Pressing **Previous** will cause the program to return to the Swap form.

**Note: The Invert options will configure the axis as it is currently displayed. In other words, if the Swap function has been set to True (Figure 37) then setting the X Direction to True in the invert screen will invert what was originally the Y-axis.**

#### 6.2.4 Reference Setting

**Please note, for these options to work correctly, the following must be done:**

- 1. Enter the Sensor Address the settings will be applied to on the main screen.**
- 2. Enter only whole numbers, e.g., 38.00, not 38.**
- 3. Ensure that the PC is set to use a period as a separator, not a comma.**

The **Reference Setting** feature (Figure 39) allows the output of the unit to be adjusted for a given value. This feature is often used to maintain contiguous data when replacing units in service or when moving units for regular cleaning or other maintenance. If the Reference feature is not used, the values must be adjusted during post-processing to account for differences in the measurements after moving or replacing a unit.

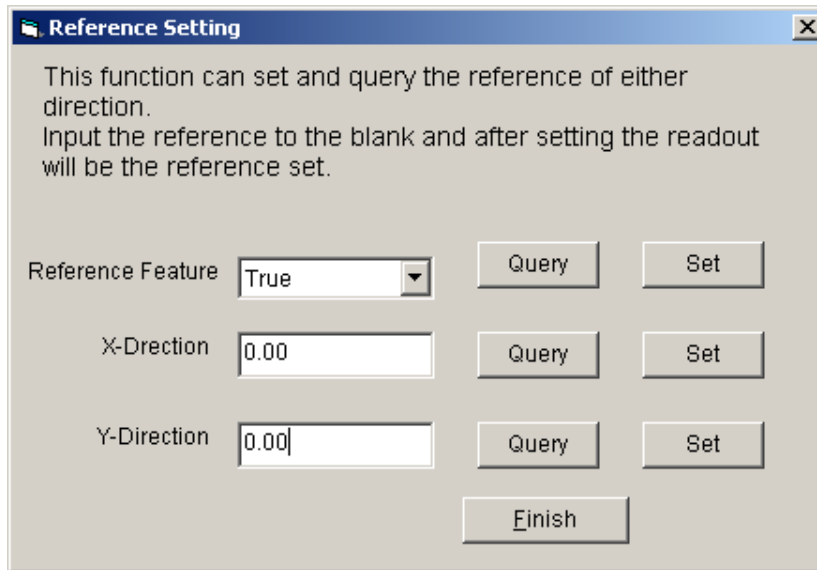

Figure 39 - Reference Setting Window

Enter the desired value for the X-axis reference in the **X-Direction** field then press the **Set** button adjacent to the value. Pressing the **Query** button will display the current setting. The reference for the Y-axis can be entered into **Y-Direction** field in the same manner.

*AFTER* the X-Direction and Y-Direction references have been set, the **Reference Feature** field may be set. Choose **True** to turn the reference feature on, **False** to turn it off. Once the desired setting has been chosen, press the **Set** button adjacent to Reference Feature. Pressing the **Query** button will display the current setting.

If the Reference Feature has been set to True, the program will configure the unit to use the new X and Y-direction values as the starting values for the pendulum readings, as well as for the 4-20mA output. A dialog box will appear showing the internal offset (the current absolute measurement) that will be used to adjust the output in order to achieve the desired Reference output (Figure 40). Click **OK** to continue.

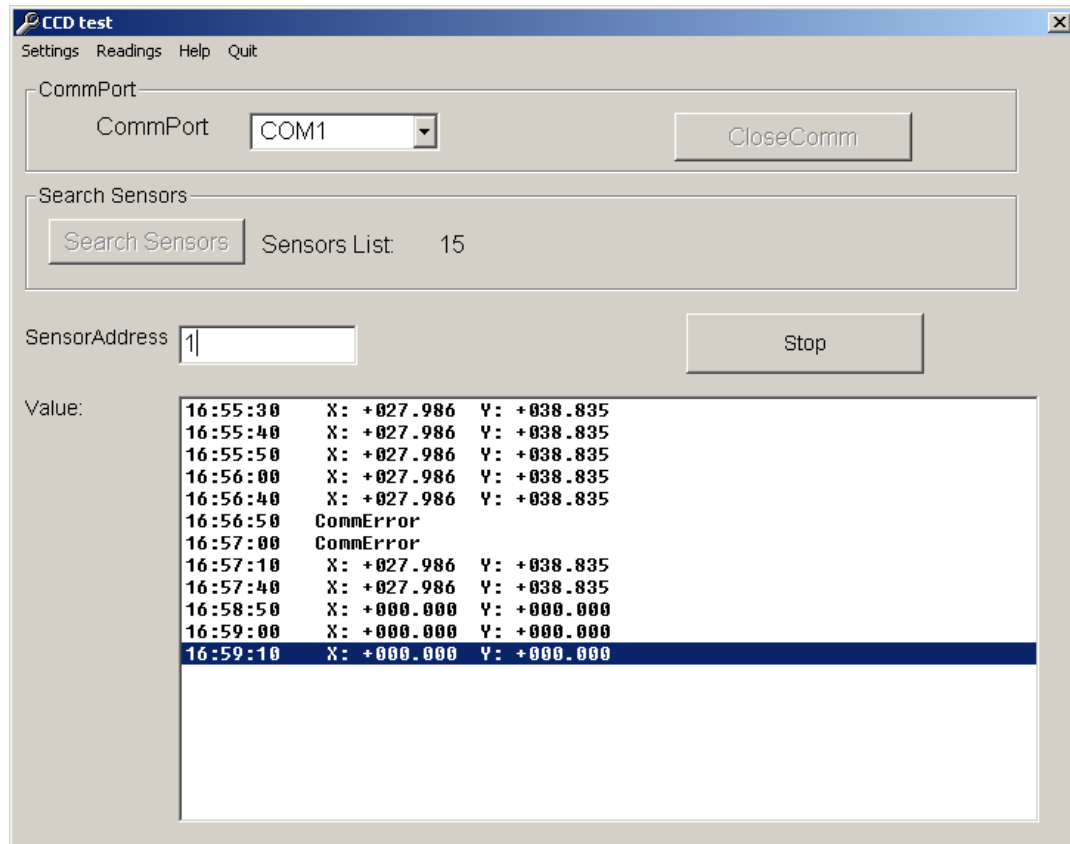

Figure 40 - Reference Setting Message

Once the Reference values have been set, the pendulum display will update to account for the new Reference values. Close the form by clicking the X in the upper right corner.

The program will return to the Reference Setting window (Figure 39). Click **Finish** to return to the main screen.

Upon returning to the main screen the X and Y values will be updated according to the values entered (Figure 41).



**Figure 41 - Updated X and Y Values Coinciding with Reference Changes**

The following sequence is an example of how the References feature can maintain contiguous data:

- 1) The values from the currently installed pendulum are 27.986 and 38.835 millimeters for X and Y respectively. The References feature is NOT being used; therefore, these are absolute values.
- 2) The unit is removed, cleaned, and reinstalled. The new readings are 25.456 and 31.894 for X and Y respectively.
- 3) Using the Reference Setting form, the X and Y-direction References are entered as 27.986 and 38.835 respectively. The Reference Feature is then set to True. The display will update to show the measurements last recorded prior to removing the unit. This provides for contiguous data without the need to apply post-processing offset corrections.

(To show changes in movement after installation, configure the fields as shown in Figure 39.)

### 6.2.5 Clock Setting

The Clock Setting function is useful when the pendulum is logging readings in its internal memory. Select **Clock Setting** from the settings dropdown on the main screen to display the Set Time form (Figure 42).

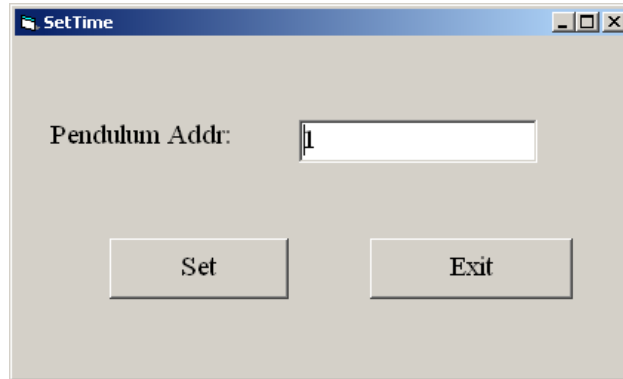

Figure 42 - Set Pendulum Time to Match PC Clock

To match the internal pendulum clock to the PC clock, enter the desired pendulum address and press **Set**.

Click **Exit** to return to the main form.

### 6.3 Quitting the Program

Before closing the program, stop the immediate readings by clicking on **Stop** and then close communications to the Comm port by clicking **CloseComm**.

To exit the CCDTest software, click on **Quit** in the upper portion of the screen.

## **7. TROUBLESHOOTING**

The 6850 Pendulum Readout requires no regular maintenance other than periodic checks to see that the optics are clean. Using a computer and the software supplied with the readout it is possible to initiate a ‘grayscale scan’ that looks at all the pixels of the CCD output and determines if the optics require cleaning.

If it is determined that cleaning is necessary then it can be done with a clean, soft cloth, slightly moistened with water if necessary. **Do not use any chemical organic solutions in the cleaning process.**

The Pendulum Readout is equipped with a self-diagnosis feature; when a fault occurs, the display will show the corresponding error code. Use Table 4 below to trace and correct the fault. If the fault still exists after performing the suggested remedy, return the readout to the manufacturer.

Err2, Err4, and Err6 may alternate on the display if the ambient light is too bright.

<b>Displayed Error Code or fault symptom</b>	<b>Problem</b>	<b>Solution</b>
Err2	The ambient light is too bright.	Enhance the light shielding methods or use an additional light shield.
Err3	The light is too weak.	Return to manufacturer for repairs.
Err4	There is no shadow indicating that the pendulum wire has moved out of range.	Readjust the position of the readout.
Err5	A fault has occurred in the CCD image sensor.	Return to the manufacturer for repair.
Err6	There are too many shadows; there may be some debris or water drops blocking the optical paths.	Clean any debris or water found in the CCD chamber or on the wire.
Displays are blank	Power supply has failed.	Restore Power.
Displays work but communications have failed.	The readout address may be incorrect, or there is a fault in the communication line.	Reset the address, or check the communication cable.
No analogue output	A fault has occurred in the readout box analogue circuit.	Return to the manufacturer for repair.

**Table 4 - Error Codes and Troubleshooting Information**

## **APPENDIX A. TECHNICAL SPECIFICATIONS**

<b>Measuring Range:</b>	50 mm x 100 mm x 50 mm (2" x 4" x 2")
<b>Resolution:</b>	0.01 mm (.0004")
<b>Precision:</b>	0.1 mm (.004")
<b>Wire Diameter:</b>	1.0 mm to 9.9 mm (.04" to 3.9")
<b>Electrical drift:</b>	Zero
<b>Operating Temperature:</b>	-15 °C to +60 °C
<b>Relative Humidity:</b>	100%RH
<b>Sensor:</b>	CCD
<b>Outputs:</b>	On-site LED display, RS485 and 4-20mA port
<b>Sample Frequency:</b>	Once/10 seconds to Once/day, programmable
<b>Data Storage capacity:</b>	1200 readings on non-volatile RAM. Each reading has values of X, Y, Z, date and time.
<b>Power Supply:</b>	85 to 265VAC, 50 to 60Hz, 10Watts
<b>Enclosure:</b>	Weatherproof, painted steel (Red)
<b>Dimension:</b>	480 x 430 x 220 mm high (18.9" x 16.9" x 8.7")
<b>Weight:</b>	16 kg (35.3 lb.)

## **APPENDIX B. MULTILOGGER SOFTWARE CONFIGURATION**

***NOTE: These Instructions were written for the 2-axis pendulum but can be extrapolated to the 3-axis.***

The Model 6850 Pendulum includes an RS-485 (half-duplex) interface as well as dual 4-20mA outputs. The pendulum may be integrated to the Campbell MCU using the 4-20mA output or RS-485. RS-485 is recommended as it eliminates any analog measurement error from the readings.

### **B.1 Overview**

Using Sensor Application Note #16 will provide information to help integrate the Geokon Model 6850 Pendulum into a Campbell CR6, CR800, or CR1000 based monitoring system when configured using MultiLogger. It will include wiring details as well as programming details to deploy this equipment.

### **B.2 Wiring**

Table 5 shows the pinout for the output connector found on the base of the cabinet.

<b>Pin</b>	<b>Description</b>	<b>Color (Pre-assembled)</b>
A	X-Axis 4-20mA Output	Red
B	Ground	Red's Black
C	Y-Axis 4-20mA Output	White
D	Ground	White's Black
E	No Connection	
F	RS-485-	Green
G	RS-485+	Green's Black
H,J,K	No Connection	

**Table 5 - Output Connector Pinout**

### B.3 4-20mA Configuration

Direct Connect Channels are used for configuring the pendulum measurements. Each channel corresponds to an X or Y-axis measurement; this provides for including the math to convert the output from mA to millimeters or to other engineering units. See Figure 43 for a diagram of the 4-20ma connection.

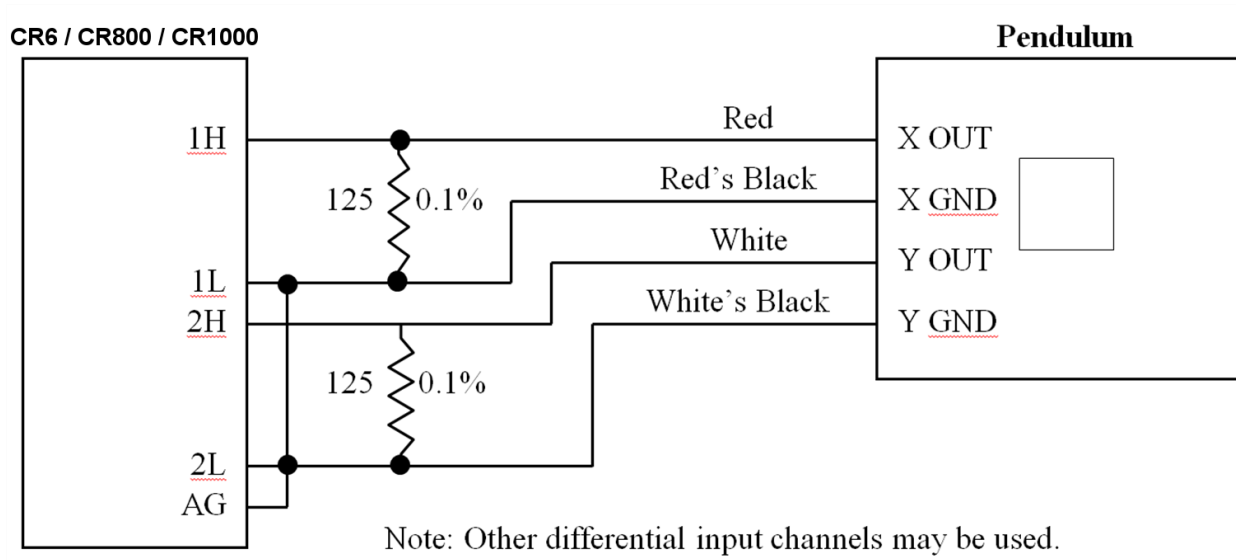

Figure 43 - 4-20mA Connection Diagram

Figure 44 shows the **Linear Coefficients** used to convert from current to millimeters. Configure both the X-axis (Channel 1) and Y-axis (Channel 2) in this manner.

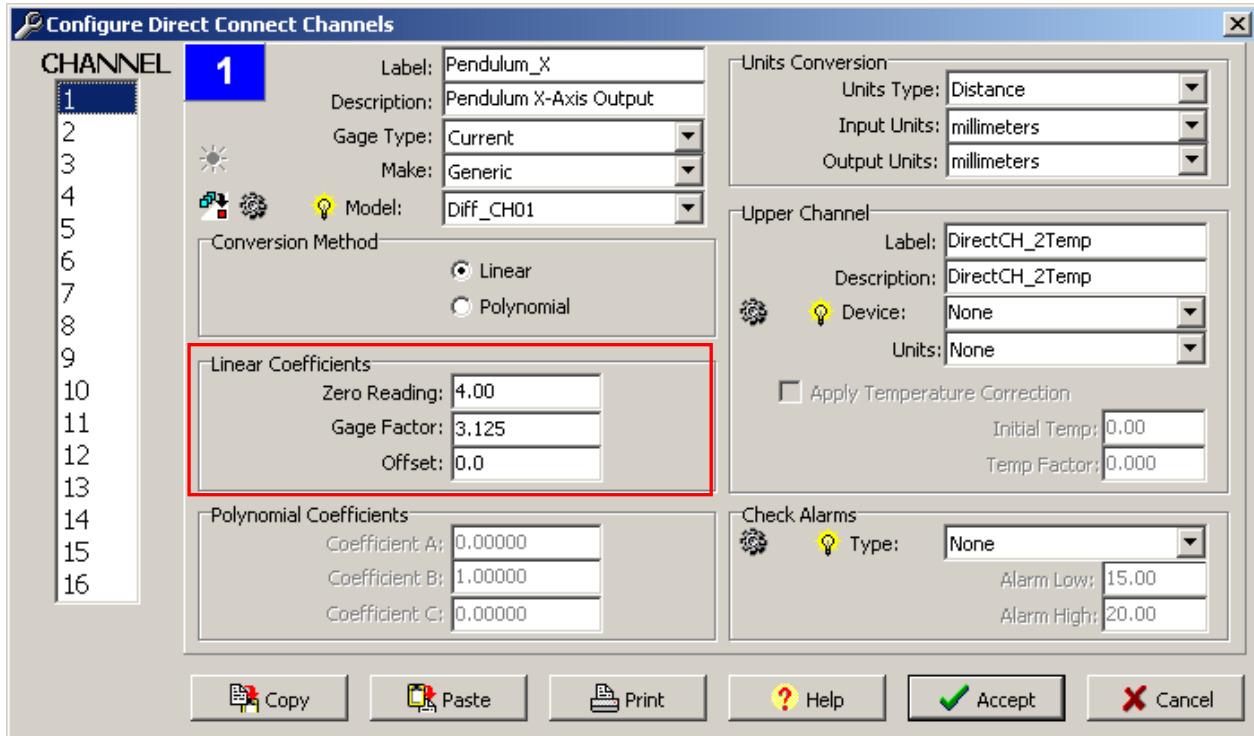

Figure 44 - Linear Coefficients



## B.4 RS-485 Configuration

Pendulum RS-485 support is only provided for the CR6, CR800, and CR1000 control modules. The gauge types referenced in the following section are found in MultiLogger V4.2 or higher. Contact Canary Systems directly to obtain the current version of MultiLogger software.

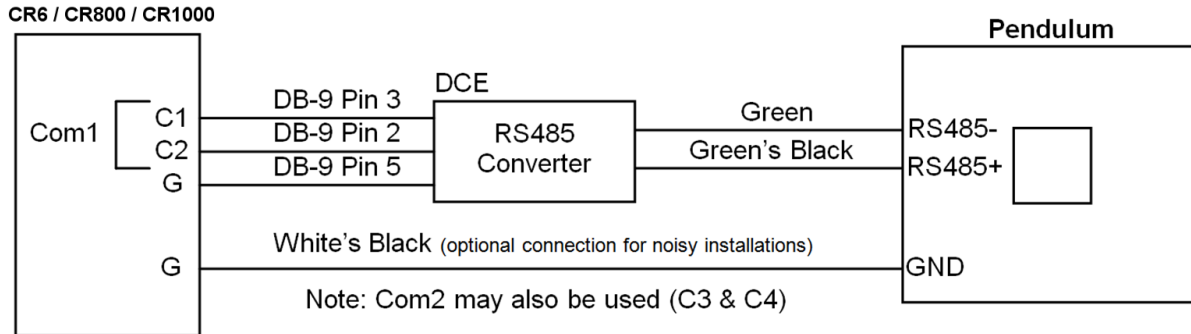

Figure 45 - RS-485 Connection Diagram

Generally, the **Direct Connect Channels** are used for configuring the pendulum measurements. There are two methods of configuring them, dependent upon whether the resultant values must be converted to other units, or if alarms must be configured on each measurement. The output units of the pendulum are **millimeters**.

Figure 46 below shows a typical channel configuration to read the X and Y-axis outputs of a pendulum connected to Com1 on the control module (Control Ports C1 and C2 used for communications) at address 01. Addresses 1-16 are supported – contact Canary Systems if the intended application has more than 16 pendulums per network.

Note the availability of gauge types for COM1 (Control Ports C1 and C2) and COM2 (Control Ports C3 and C4). The CR800 has two COM ports, the CR1000 has four. Contact Canary Systems if the intended application requires the use of COM3 (Control Ports C5 and C6) or COM4 (Control Ports C7 and C8) on the CR1000.

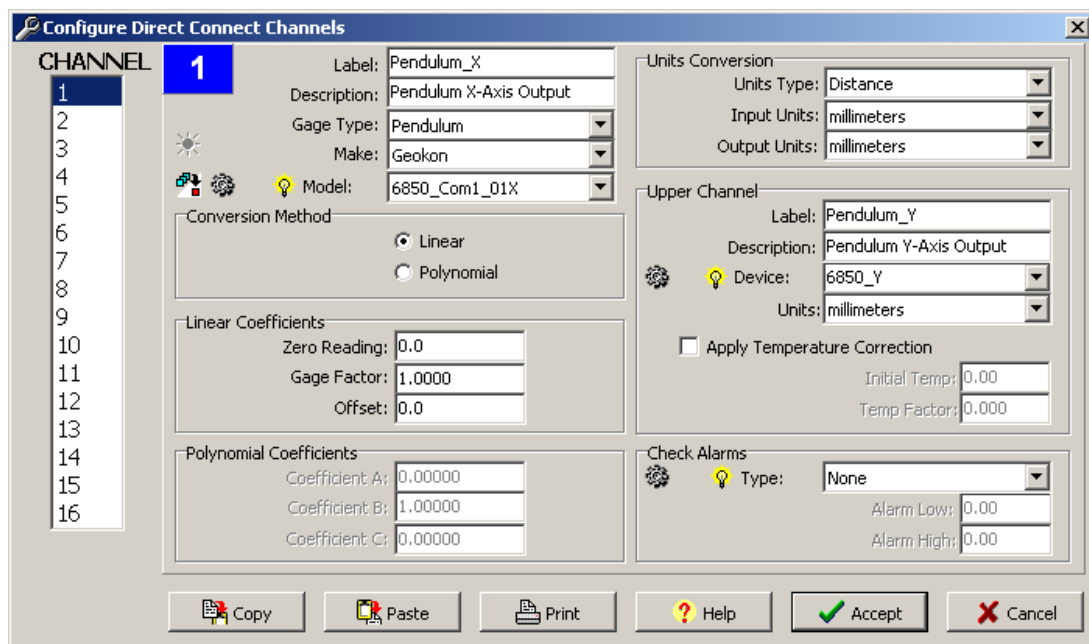

Figure 46 - Typical RS-485 Channel Configuration

The configuration shown in Figure 46 allows converting the X-axis values using the Conversion Method and/or the Units Conversion, as well as configuration of alarms using the Check Alarms options. Note that when using a single channel configuration, the type of adjustments listed above, including Check Alarms, will not be available for the Y-axis value. If the application of the pendulum requires conversions and/or Check Alarms settings for the Y-axis, then the Y-axis will need to be configured as a separate Channel. Configuring the Y-axis as a separate channel limits the number of pendulums that can be configured to eight. Channel 1 would be used for the X-axis, and would be configured as shown in Figure 47.

The screenshot shows the 'Configure Direct Connect Channels' dialog box with Channel 1 selected. The configuration is as follows:

- Channel List:** Channels 1 through 16 are listed on the left. Channel 1 is highlighted.
- Channel 1 Details:**
  - Label:** Pendulum\_X
  - Description:** Pendulum X-Axis Output
  - Gage Type:** Pendulum
  - Make:** Geokon
  - Model:** 6850\_Com1\_01X
- Conversion Method:**
  - Linear
  - Polynomial
- Linear Coefficients:**
  - Zero Reading:** 0.0
  - Gage Factor:** 1.0000
  - Offset:** 0.0
- Polynomial Coefficients:**
  - Coefficient A:** 0.00000
  - Coefficient B:** 1.00000
  - Coefficient C:** 0.00000
- Units Conversion:**
  - Units Type:** Distance
  - Input Units:** millimeters
  - Output Units:** millimeters
- Upper Channel:**
  - Label:** DirectCH\_2Temp
  - Description:** DirectCH\_2Temp
  - Device:** None
  - Units:** None
  - Apply Temperature Correction
  - Initial Temp:** 0.00
  - Temp Factor:** 0.000
- Check Alarms:**
  - Type:** Low and High
  - Alarm Low:** 15.00
  - Alarm High:** 20.00

Buttons at the bottom: Copy, Paste, Print, Help, Accept, Cancel.

Figure 47 - Channel 1, X-axis Configuration

Channel 2 would then be used to support the Y-axis measurement, and would be configured as shown in Figure 48.

The screenshot shows the 'Configure Direct Connect Channels' dialog box with Channel 2 selected. The configuration is as follows:

- Channel List:** Channels 1 through 16 are listed on the left. Channel 2 is highlighted.
- Channel 2 Details:**
  - Label:** Pendulum\_Y
  - Description:** Pendulum Y-Axis Output
  - Gage Type:** Pendulum
  - Make:** Geokon
  - Model:** 6850\_Y
- Conversion Method:**
  - Linear
  - Polynomial
- Linear Coefficients:**
  - Zero Reading:** 0.0
  - Gage Factor:** 1.0000
  - Offset:** 0.0
- Polynomial Coefficients:**
  - Coefficient A:** 0.00000
  - Coefficient B:** 1.00000
  - Coefficient C:** 0.00000
- Units Conversion:**
  - Units Type:** Distance
  - Input Units:** millimeters
  - Output Units:** millimeters
- Upper Channel:**
  - Label:** DirectCH\_2Temp
  - Description:** DirectCH\_2Temp
  - Device:** None
  - Units:** None
  - Apply Temperature Correction
  - Initial Temp:** 0.00
  - Temp Factor:** 0.000
- Check Alarms:**
  - Type:** Low and High
  - Alarm Low:** 15.00
  - Alarm High:** 20.00

Buttons at the bottom: Copy, Paste, Print, Help, Accept, Cancel.

Figure 48 - Channel 2, Y-axis Configuration

## B.5 Error Codes

The pendulum has several error codes that indicate problems with the installation or the unit. These codes will be shown on the pendulum display and have equivalent values when automating the systems using MultiLogger.

Use Table 6 below to trace and correct the fault. If the fault still exists after performing the suggested remedy, return the readout to the manufacturer.

Err2, Err4, and Err6 may alternate on the display if the ambient light is too bright.

<b>Displayed Error Code or fault symptom</b>	<b>MultiLogger Code</b>	<b>Problem</b>	<b>Solution</b>
Err2	-99992	The ambient light is too bright.	Enhance the light shielding methods or use an additional light shield.
Err3	-99993	The light is too weak.	Return to manufacturer for repairs.
Err4	-99994	There is no shadow indicating that the pendulum wire has moved out of range.	Readjust the position of the readout.
Err5	-99995	A fault has occurred in the CCD image sensor.	Return to the manufacturer for repair.
Err6	-99996	There are too many shadows; there may be some debris or water drops blocking the optical paths.	Clean any debris or water found in the CCD chamber or on the wire.
Displays are blank	-99999	Power supply has failed or there is a fault in the communication line.	Restore Power and check the communication cable.

**Table 6 - MultiLogger Error Codes**

## **APPENDIX C. PENDULUM COMMANDS**

***NOTE: These Instructions were written for the 2-axis pendulum but can be extrapolated to the 3-axis.***

Terminal emulation programs may be programmed with the pendulum commands to help with troubleshooting and configuration of the units. Table 7 below shows typical commands and responses. Communication parameters are **9600 bps, eight data bits, one stop bit, no parity bit**. The baud rate of the pendulum is fixed at 9600 bps.

All commands are prefaced with a colon, followed by the address of the unit in hexadecimal notation, and then by the command and any corresponding parameters. The command is terminated with “FF” <CR> <LF>. Responses include a two-byte signature (“gg”).

<b>Command</b>	<b>Command</b>	<b>Response</b>
Set Address, where; aa = Current Address (01-FF) bb = New Address (01-FF)	:aa02bbFF	:aa02bbFB
Get X and Y-axis readings, where; aa = Address s = Sign (+/-) xxx.xxx = X-axis yyy.yyy = Y-axis gg = Signature	:aa2101FF	:aa2101sxxx. xxxsyyy.yyygg
Set X-axis Parameters, where; aa = Address ww = Wire diameter in mm (2 digits no decimal, e.g. 1.0 mm = 10) ee = Error in mm (2 digits no decimal, e.g. 0.5 mm = 05)	:aa67wwee010000FF	:aa67wwee010000gg
Set Y-axis Parameters (Same as X-axis.)	:aa69wwee010000FF	:aa69wwee010000gg
Query Reference Setting, where; aa = Address	:aa76FF	:aa76rrgg
Set Reference False	:aa7500FF	:aa7500gg
Set Reference True	:aa7501FF	:aa7501gg
Set X-Axis Reference, where; aa = Address s = Sign (+/-) xxx.xxx = X-axis reference value (Entered as an offset.)	:aa71Sxxx.xxxFF	:aa71Sxxx.xxxgg
Set Y-Axis Reference, where; aa = Address s = Sign (+/-) yyy.yyy = Y-axis reference value (Entered as an offset.)	:aa73Syyy.yyyFF	:aa73Syyy.yyygg
Read/Set Clock, where; aa = Address yy = Year mm = Month dd = Day hh = Hour mm = Minute ss = Second	:aa04FF :aa03yyymmddhhmmssFF	:aa04yyymmddhhmmssgg :aa03yyymmddhhmmssgg

**Table 7 - Commands for Terminal Emulation Programs**

## **APPENDIX D. CR6 PROGRAMMING EXAMPLE**

### **'CR6 Program**

**'Read the X, Y and Z output of a Geokon Geopendulum connected to COM1 (C1 & C2) at Address 01**

Public I 'Counter

Public sInStr As String \* 30 'String used to record incoming data from pendulum

Public Var(6) 'Temporary variables, used in error code calculation

Public Result(3) 'Data points stored in the Data Table X, Y, Z, axis

DataTable (Test,True,1000)

### **'Store X Y and Z axis results**

Sample (3,Result(),IEEE4)

EndTable

### **'Main Program**

BeginProg

Alias Result(1) = X\_Axis

Alias Result(2) = Y\_Axis

Alias Result(3) = Z\_Axis

### **'Open our port**

SerialOpen (ComC1,9600,0,1000,255)

Scan (5,Sec,0,0)

### **'Clear the buffer**

SerialFlush (ComC1)

### **'Send Reading command of first set of data characters**

SerialOut (ComC1,":012101FF" + CHR(13) + CHR(10),"",0,0)

### **'Listen to communication line for half a second to give time to receive message.**

SerialIn (sInStr,ComC1,50,"",30)

If Len (sInStr) >= 23 Then

**'Remove E from string to properly split the string as it is registered as an  
'exponential.**

sInStr = Replace (sInStr,"E","+")

**'Split the string to three parts**

SplitStr (Var(1),sInStr,"",3,0)

### **'Check for error codes for Var(2) and Var(3)**

For I = 2 To 3

**'Check result against error codes**

If Var(I) = 2000000 Then

**'Error code for Ambient light is too bright**

Var(I) = -99992

ElseIf Var(I) = 3000000 Then

**'Error code for Projected light is too weak**

Var(I) = -99993

ElseIf Var(I) = 4000000 Then

**'Error code for Wire is out of range**

Var(I) = -99994

ElseIf Var(I) = 5000000 Then

```

    'Error code for Fault has occurred in CCD element
    Var(I) = -99995
    ElseIf Var(I) = 6000000 Then
        'Error code for Shadows interfering with measurement
        Var(I) = -99996
    EndIf
Next

Else
    'When a returned string is incomplete, communication breakdown error
    Var(2) = -99999
    Var(3) = -99999
EndIf

'Store recorded variable into X axis
X_Axis = Var(2)

'Store recorded variable into Y axis
Y_Axis = Var(3)

'Delay a short time between readings
Delay (0,250,mSec)

'-----
'Include this code if Z axis is required
'-----

'Clear the buffer
SerialFlush (ComC1)

'Send Reading command on second set of data characters
SerialOut (ComC1,":012102FF" + CHR(13) + CHR(10),"",0,0)

'Listen to communication line for half a second to give time to receive message.
SerialIn (sInStr,ComC1,50,"",30)

If Len (sInStr) >= 23 Then
    'Remove E from string to properly split the string as it is registered as an
    'exponential when split by numeric values.
    sInStr = Replace (sInStr,"E","+")

    'Split the string to three parts
    SplitStr (Var(4),sInStr,"",3,0)

    'Check result against error codes
    If Var(5) = 2000000 Then
        'Error code for Ambient light is too bright
        Var(5) = -99992
    ElseIf Var(5) = 3000000 Then
        'Error code for Projected light is too weak
        Var(5) = -99993
    ElseIf Var(5) = 4000000 Then
        'Error code for Wire is out of range
        Var(5) = -99994
    ElseIf Var(5) = 5000000 Then
        'Error code for Fault has occurred in CCD element
        Var(5) = -99995
    ElseIf Var(5) = 6000000 Then

```

```
'Error code for Shadows interfering with measurement
Var(5) = -99996
EndIf

Else
'When a returned string is incomplete, communication breakdown error
Var(5) = -99999
EndIf

'Store recorded variable into Z axis
Z_Axis = Var(5)
'-----
'End of Z axis code
'-----

'Call Output Table(s)
CallTable Test
NextScan
EndProg
```

**APPENDIX E. CR800/CR1000 PROGRAMMING EXAMPLE**

(gt\_6850\_com1\_01x.crl instruction file)

```

'Read the X and Y output of a Geokon Geopendulum connected to COM1 (C1 & C2) at Address 01
'Open our port
SerialOpen (Com1,9600,0,1000,255)

'Clear our counter
ScratchLoc(1) = 0

'Loop 5 times to get measurement
Do
    'Make sure buffer is clear
    SerialFlush(Com1)

    'Send Reading command
    SerialOut (Com1,":012101FF"+CHR(13)+CHR(10),"",0,0)

    'Receive response with .25 second timeout
    SerialIn(sInBuf,Com1,25," ",30)

    'Check for enough characters
    if Len(sInBuf) >= 23 then
        'Split out response values
        Splitstr(ScratchLoc(2),sInBuf,"",3,0)

        'Check for error codes
        if ScratchLoc(3) = 2000000 or ScratchLoc(4) = 2000000 then
            ScratchLoc(3) = -99992
            ScratchLoc(4) = -99992
        endif
        'Check for error code
        if ScratchLoc(3) = 3000000 or ScratchLoc(4) = 3000000 then
            ScratchLoc(3) = -99993
            ScratchLoc(4) = -99993
        endif
        'Check for error code
        if ScratchLoc(3) = 4000000 or ScratchLoc(4) = 4000000 then
            ScratchLoc(3) = -99994
            ScratchLoc(4) = -99994
        endif
        'Check for error code
        if ScratchLoc(3) = 5000000 or ScratchLoc(4) = 5000000 then
            ScratchLoc(3) = -99995
            ScratchLoc(4) = -99995
        endif
        'Check for error code
        if ScratchLoc(3) = 6000000 or ScratchLoc(4) = 6000000 then
            ScratchLoc(3) = -99996
            ScratchLoc(4) = -99996
        endif
    endif

    'No valid response
    Else
        ScratchLoc(3) = -99999
        ScratchLoc(4) = -99999
    EndIf

    'Short delay before trying again or exiting
    Delay(0,250,mSec)

    'Increment our counter
    ScratchLoc(1) = ScratchLoc(1) + 1

Loop Until (ScratchLoc(1) >= 5) OR (ScratchLoc(3) > -99990)

'Copy our reading whatever it is (ScratchLoc(4) holds Y-Axis value)
mlReading = ScratchLoc(3)

'Close our serial port
SerialClose (Com1)

```



## **APPENDIX F. MOUNTING BRACKET (OPTIONAL ACCESSORY)**

Mounting brackets can be made locally, or by Geokon (if the necessary dimensions and orientation are provided). The following information is to be used as a general guide for assembly only, as custom mounting brackets may require a different procedure. Generally, Geokon provided mounting brackets consist of two triangular pieces made from 45 mm x 45 mm angle iron, which are connected together by one strut at the wall and a U shaped top plate (see Figure 49).

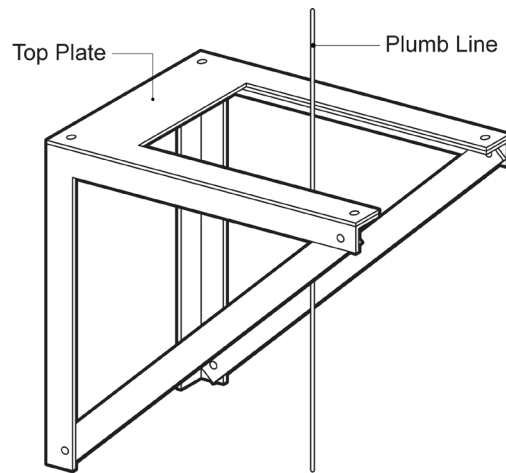

**Figure 49 - Mounting Bracket**

### **F.1 Mounting Bracket Installation**

The clearance between the wall and the pendulum wire needs to be at least 230 mm (9"), large enough so that there is space enough for the readout cabinet, bearing in mind the orientation convention found in Section 4.2.

- 1) Drill four, 12 mm (1/2") diameter holes in the wall, matching them to the four slots in the bracket uprights. (The positioning of the holes must be done very carefully to ensure that the pendulum wire will fall near the centerline of the space in the top plate.)
- 2) Tighten the provided expansion bolts into the 12 mm (1/2") holes.
- 3) Slide the bracket assembly behind the pendulum wire.
- 4) Position the slots in the two bracket uprights around the anchor bolts.
- 5) Bolt the plate to the brackets using the flat head screws provided.
- 6) Use a spirit level to level the plate.
- 7) Tighten the nuts onto the anchor bolts.
- 8) Attach the adhesive backed Velcro strips to the top plate so that they will contact the strips attached to the Pendulum readout when the readout is put into position.